

PRODUCT CATALOGUE



Introducing our range of Roband, Austheat & Robatherm food service equipment.

Proudly Australian made, we are pleased to present our range of modern, stylish and functional Roband and Austheat food service equipment. Representing more than five decades of engineering excellence, this collection provides customers with the opportunity to own and use the very best.

An icon of the Australian food service industry, the Roband name is instantly associated with quality, innovation, reliability and service. This reputation, coupled with our strong history, is your guarantee of a quality product that is backed by a strong, customer focused organisation.



All Roband and Austheat products are manufactured in Australia with national and international distribution to over twenty countries. Roband Australia is at the forefront of innovation and development.

Roband Australia is also pleased to present the range of Robatherm hot water urns and a percolator, manufactured overseas to our exacting standards.

We are committed to bringing you the very latest in technology and design and we take great pride in knowing that our products can make a significant contribution to your business success.



Contents

ROBAND® 



Milkshake & Drink Mixers	4-5
Grill Stations	6-10
Grill Max Wide-Mouth Toaster	11
Grill Max Toasters - Stainless Element.....	12
Grill Max Toasters - Glass Element.....	13
Conveyor Toasters.....	14
Eclipse Bun & Snack Toasters	15
Sycloid® Toasters	16-18
Vertical Toasters.....	19
Salamander.....	19
Griddles.....	20-21
Griddle Toasters	22-23
Fryers	
Frypods	26-27
F Series.....	28-29
Donut	29
Pie & Food Warmers	
Pie Master Pie & Food Warmers	30
Pie Warmer & Merchandiser	31
Hammertone Finish Pie Warmers.....	31
Carving Station.....	32
Chip Warmer	32
Multi-Function Chip & Food Warmer.....	33
Boiling Hot Plates.....	34
Coffee Warmer	34
Pasta Master/Vegetable Blancher	35
Hot Dog & Bun Warmers.....	35

AUSTHEAT



Freestanding Electric Fryers	58-61
Freestanding Hotplate/Grill.....	62-63
Operating Specifications and Disclaimers.....	64
Warranty Information.....	65

Heat Lamps	
Quartz Heat Lamp Assemblies.....	36-37
Infra-Red Heating Assemblies.....	38-39
Fluorescent Lighting Assemblies.....	40
Optional Mount Kit	40
Heat Lamp Stands.....	41
Modular Heat Lamp	42
Individual Heat Lamps.....	42
Bain Maries	
Counter Top	44-45
Sauce Warmer	46
Chocolate Bain Maries	46
Hot	47
Refrigerated	47
Accessories/Pan Layout Guide.....	54-56
Food Display Bars	
Straight Glass Hot	
~ Single Row	48
~ Double Row	48
Straight Glass Refrigerated	49
Curved Glass Hot.....	50
Curved Glass Refrigerated	51
Square Glass Hot.....	52
Square Glass Refrigerated.....	53
Accessories/Pan Layout Guide.....	54-56
Rotisserie	57



ROBATHERM

Double Skinned Hot Water Urns	24
Percolator	25

Milkshake & Drink Mixers



Roband milkshake mixers are the ideal machine for making perfect thickshakes or milkshakes every time. The Saturn beater produces extra fluffy shakes using minimal ingredients, time after time. Merging style, power and performance these mixers are a must for cafes and fast food outlets.

FEATURES

- Powerful two-speed motor, 18,000 RPM on low and 22,000 RPM on high speed
- Saturn beater for extra fluffy shakes, stainless steel beaters also included for use with ice cream
- Separate two-speed on/off switch with protective cover
- Available in red, white, black, graphite, seaspray & metallic
- Easy-clean base for cleaning spillage
- High performance stainless steel mixing spindle
- Takes standard 710 ml (24 fl.oz.) cups without tilting to remove
- Stainless steel cup included
- 'Hands free' operation when mixing cup is resting on the cup support

DIMENSIONS

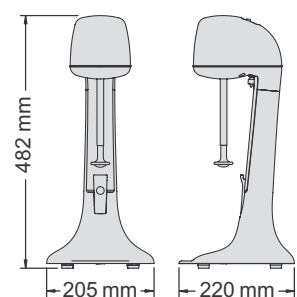



DM21S
Seaspray

DM21B
Black

DM21M
Metallic

Saturn beater for extra fluffy shakes

Stainless steel wave beater for soft serve ice cream

Stainless steel conical beater for thickshakes



SPECIFICATIONS

MODEL	COLOUR	POWER Watts	CURRENT Amps
DM21W	White	150	0.7
DM21B	Black	150	0.7
DM21R	Red	150	0.7
DM21G	Graphite	150	0.7
DM21S	Seaspray	150	0.7
DM21M	Metallic	150	0.7

Easy-clean base for cleaning spillage



Two-speed on/off switch with protective cover



Grill Stations

The modern, stylish Roband Grill Station is available in six or eight slice size models. The Roband range sets the benchmark for commercial contact grills. The versatile unit rapidly toasts sandwiches, paninis and focaccias, in addition to producing beautifully seared and grilled tender meat, poultry and fish. Featuring elements embedded directly into smooth, high pressure die-cast aluminium plates, the cooking surface produces an even, extremely efficient heat transfer ensuring food is cooked rapidly with even colouration.

The Roband Grill Station truly is a must-have for cafes, takeaways, sandwich shops or anywhere that toasting and / or grilling is required.



FEATURES

- Six or eight sandwich capacity
- Quality high pressure die-cast aluminium cooking plates with cast-in elements for efficient, directional and effective heat transfer
- Precise thermostat for controlling cooking temperature
- Even temperature distribution across each plate and between the top and bottom plates
- Ability to switch between top and bottom plate operation or bottom plate only operation
- A counter-balanced top plate and an arched handle makes operating the Grill Station easy
- Easy one-handed loading and unloading of food with the top plate capable of staying partially open at an approximate 45° angle
- A load limiter that reduces the resting weight of the top plate on food being grilled or toasted
- Plate spacers are available separately for very thin contents
- High splash guard with top plate always positioned over bottom plate ensuring grease and crumbs fall onto bottom plate
- A front positioned grease collection box collects grease and crumbs and is well-positioned for easy removal and cleaning
- Small counter space requirement due to the elimination of a cumbersome back cable
- Angled control panel for clear visibility of settings
- 5 minute timer with warning bell
- Includes one premium spatula
- Optional ribbed top plate and / or Teflon® coating
- Optional non-stick Grill Sheet (PTFE) & Retainer Clip keeps the plates clean, prevents food sticking and is removable, cleanable & replaceable
- Optional side draining grease channel for high volume waste (model GC6 or GC8, see page 10)

Grill Stations cont'd

FEATURES & OPTIONS FOR ALL GRILL STATIONS

Top plate props open for easy access to food

GSA610S pictured

Plate options



Top plate always positioned over bottom plate

High splash guard



Removable grease tray

Top & bottom or bottom only plate selection

Thermostat control

Timer

Smooth plate
Teflon® coated



Ribbed top plate
Teflon® coated



Smooth plate

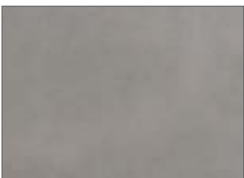

Ribbed top plate



No cumbersome back cable, reducing counter space required

Grill Stations cont'd

SPECIFICATIONS

MODEL	SLICES No.	PLATE COATING	TOP PLATE	POWER Watts	CURRENT Amps	DIMENSIONS w x d x h (mm)	BOTTOM PLATE DIMENSIONS w x d (mm)
GSA610S	6	NIL	SMOOTH	2200	9.6	435 x 490 x 220	375 x 275
GSA610R	6	NIL	RIBBED	2200	9.6	435 x 490 x 220	375 x 275
GSA610ST	6	TEFLON®	SMOOTH	2200	9.6	435 x 490 x 220	375 x 275
GSA610RT	6	TEFLON®	RIBBED	2200	9.6	435 x 490 x 220	375 x 275
GSA810S	8	NIL	SMOOTH	2300	10.0	560 x 490 x 220	500 x 275
GSA810R	8	NIL	RIBBED	2300	10.0	560 x 490 x 220	500 x 275
GSA810ST	8	TEFLON®	SMOOTH	2300	10.0	560 x 490 x 220	500 x 275
GSA810RT	8	TEFLON®	RIBBED	2300	10.0	560 x 490 x 220	500 x 275
GSA815S	8	NIL	SMOOTH	2990	13.0	560 x 490 x 220	500 x 275
GSA815R	8	NIL	RIBBED	2990	13.0	560 x 490 x 220	500 x 275
GSA815ST	8	TEFLON®	SMOOTH	2990	13.0	560 x 490 x 220	500 x 275
GSA815RT	8	TEFLON®	RIBBED	2990	13.0	560 x 490 x 220	500 x 275

Note: All bottom plates are smooth. Timer does not over-ride or control thermostat.
Maximum height when top fully open is 580 mm.

DIMENSIONS - ALL MODELS

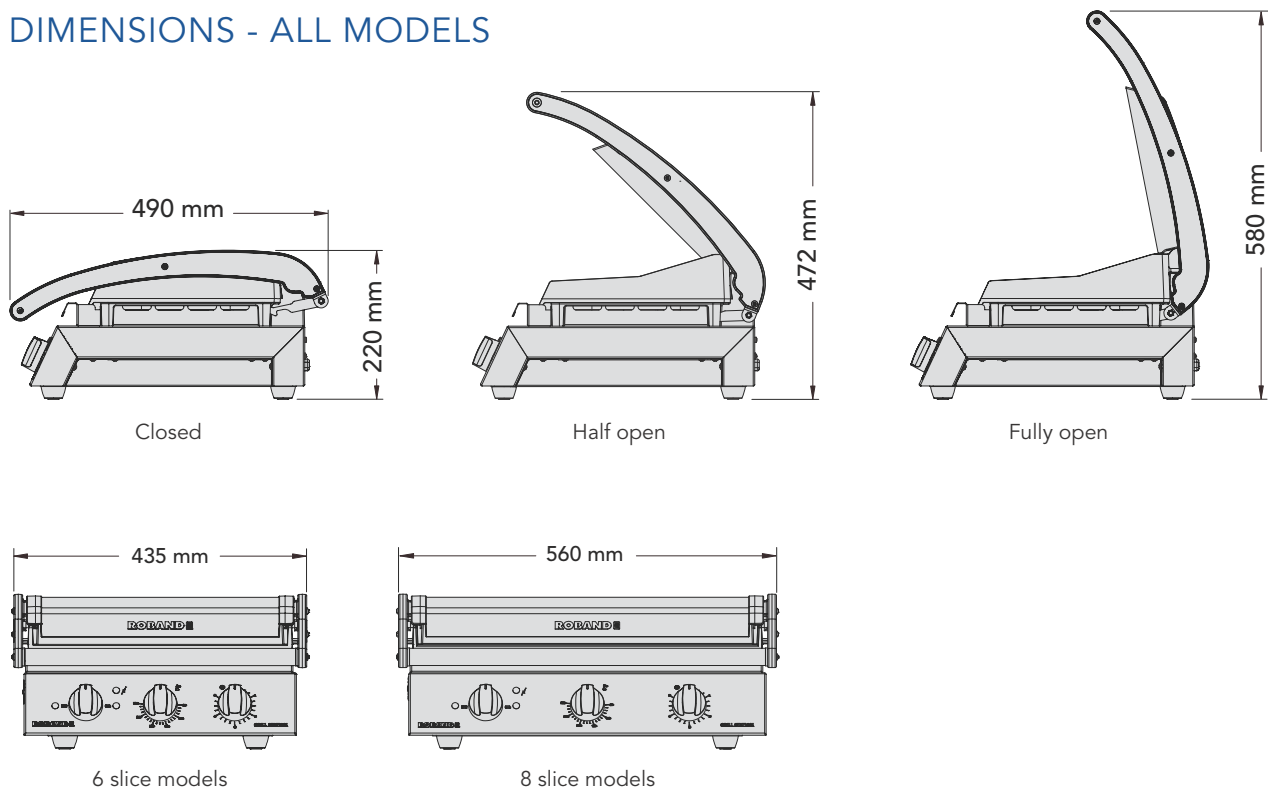

Grill Stations cont'd

FEATURES & OPTIONS FOR ALL GRILL STATIONS

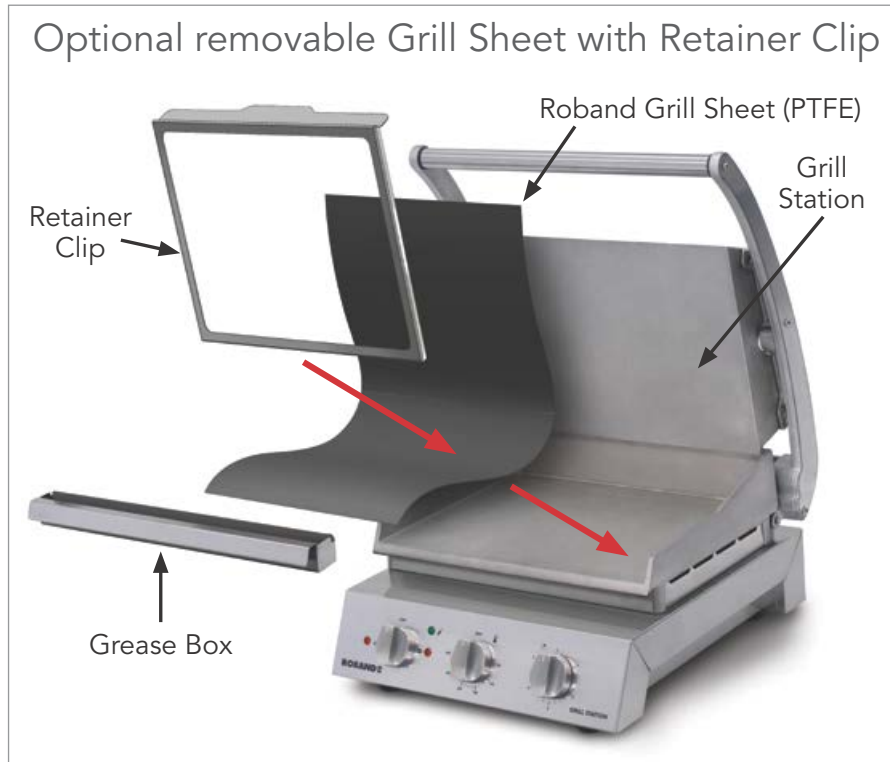

Grill Stations cont'd

FEATURES & OPTIONS FOR ALL GRILL STATIONS

Side Draining Grease Channel









Side Draining Grease Channel on 8 slice Grill Station (pan not included)

Spatula



Premium spatula pictured

ACCESSORIES

GRILL STATION ACCESSORY		MODEL TO SUIT 6 SLICE GRILL STATIONS	MODEL TO SUIT 8 SLICE GRILL STATIONS
	Sheet Retainer Clip	RC6	RC8
	Grill Sheet (PTFE) (non-stick)	PGS605 (5 pack QTY) PGS610 (10 pack QTY)	PGS805 (5 pack QTY) PGS810 (10 pack QTY)
	Side Draining Grease Channel	GC6	GC8
	Premium Spatula	SP12 (12 pack)	SP12 (12 pack)
	Rear Stand	RS630	RS830
	Plate Spacer	GSPS625 GSPS635 GSPS645	GSPS825 GSPS835 GSPS845
	Aluminium Grill Pattern Plate (suits smooth plate Grill Stations only)	GS6-P1 (a set of 2)	GS8-P1 (a set of 2)

Grill Max Wide-Mouth Toaster

With peak performance and operator safety features, these high performance wide-mouthed toasters will make your conventional toaster a thing of the past.

The wider mouth opening and larger toasting room increases menu options, and is ideal for the preparation of taller dishes. The internal fan reduces external surface temperatures.

The added feature of an electronic timer with a soft, one-touch operation allows you to set your preferred time duration.



GMW815E pictured

FEATURES

- Electronic "soft-touch" timer operation
- 5 minute timer operation
- Set and forget timer with soft one-touch operation for repeat selection
- Top and bottom OR top only heat selection
- Energy regulator control allows for choice and flexibility in heat setting
- Stylish stainless steel design ideal for front-of-house environment
- Dura-life stainless steel elements for prolonged element life
- Wide mouth opening can accommodate dishes as tall as 100 mm
- Larger toasting room enables diversity in menu planning
- Cooling fan reduces external surface temperatures for operator safety
- Removable rack runners for easy cleaning
- Removable crumb tray for easy cleaning
- Audible alarm and flashing light at the end of the cooking cycle

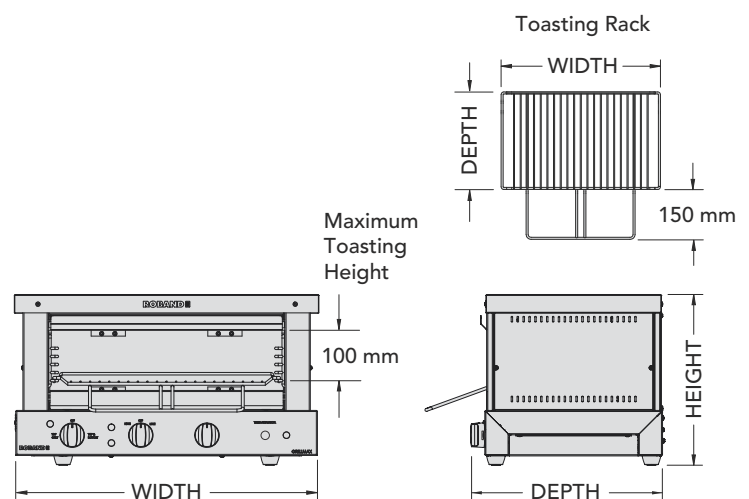
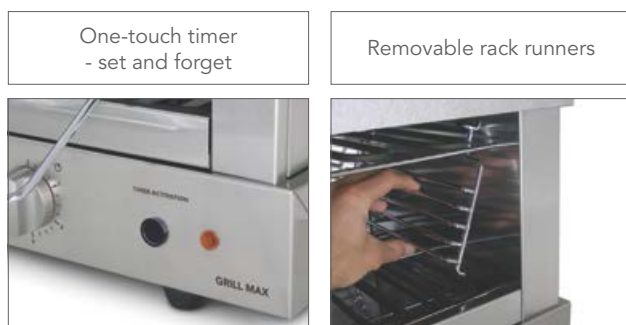

SPECIFICATIONS

MODEL	SLICES No.	POWER Watts	CURRENT Amps	TIMER Mins	DIMENSIONS w x d x h (mm)	RACK DIMENSIONS w x d (mm)	TOASTING HEIGHT Max (mm)
GMW815E	8	3450	15.0	5	625 x 390* x 350	465 x 280	100

*Depth does not include protruding rack. Including rack, depth is 505 mm.

Grill Max Toasters



The Roband Grill Max toaster series is a statement of minimalist design with great functionality. It's timeless look belies a machine that is simple to use, functional, reliable and economical.

Used for a variety of food preparation, from grilled food to open melts and

toasted sandwiches these machines are well designed to maximise speed whilst operating efficiently.

For energy efficient operation, set the energy regulator to a low setting to keep elements warm. When the timer dial is turned on, full power is delivered to elements for toasting during the timed period, overriding the low setting and with a quick heat up time. The Grill Max toaster then reverts back to the low temperature to keep food warm until ready to be removed and served.

Featuring either stainless steel elements for prolonged element life and good heat retention or glass elements for rapid heat up time. Both types of machine deliver outstanding results and the two options exist to suit customers' preferences.

FEATURES FOR STEEL ELEMENTS

- Dura-life stainless steel elements for prolonged element life
- Good heat retention - continues to radiate some heat after elements turned off to help keep food warm

SPECIFICATIONS FOR STEEL ELEMENT MODELS

MODEL	SLICES No.	POWER Watts	CURRENT Amps	TIMER Mins	DIMENSIONS w x d* x h (mm)	RACK DIMENSIONS w x d (mm)	TOASTING HEIGHT Max (mm)
GMX610	6	1960	8.5	5	485 x 315* x 315	355 x 240	79
GMX810	8	2300	10.0	5	585 x 315* x 315	455 x 240	79
GMX815	8	3360	14.6	5	585 x 315* x 315	455 x 240	79
GMX1515	15	3360	14.6	10	690 x 405* x 315	560 x 335	77

*Depth does not include protruding rack.



GMX610 pictured



GMX810 pictured



GMX1515 pictured

Grill Max Toasters cont'd

CONTROLS & FEATURES FOR ALL GMX TOASTERS

- Stylish brushed stainless steel body
- Energy regulator control
- 5 minute timer with bell
- Easy-clean removable crumb tray & reflector
- Top and bottom or top only heat selection
- Multiple rack positions

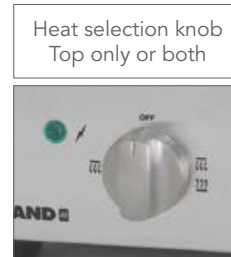
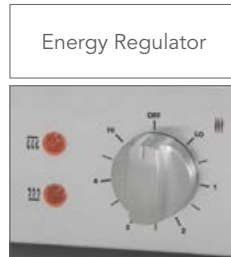

GMX810G glass element toaster pictured

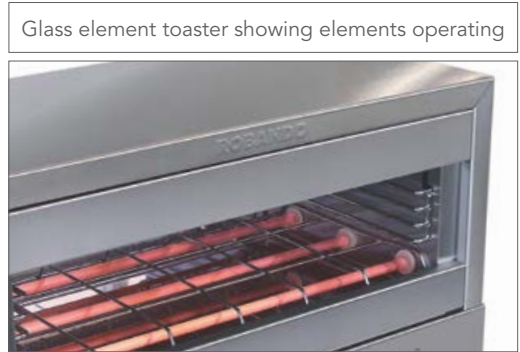

FEATURES FOR GLASS ELEMENTS

- Glass elements heat up quickly and provide instant toasting power
- Wire guard protects glass elements from accidental impact from wire rack movement
- Glass elements are wired in parallel so that the machine continues to operate if one glass element stops functioning
- Top and bottom or top only heat selection

SPECIFICATIONS FOR GLASS ELEMENT MODEL

MODEL	SLICES No.	POWER Watts	CURRENT Amps	TIMER Mins	DIMENSIONS w x d* x h (mm)	RACK DIMENSIONS w x d (mm)	TOASTING HEIGHT Max (mm)
GMX810G	8	2300	10.0	5	585 x 315* x 355	455 x 240	72

*Depth does not include protruding rack.

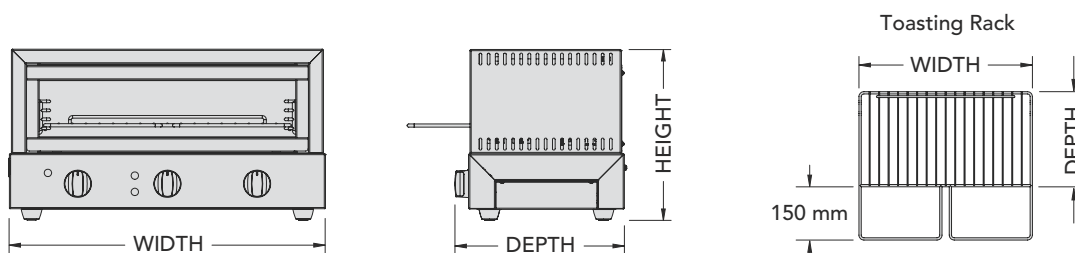

Conveyor Toasters

When it comes to serving large quantities of toasted bread, crumpets or muffins in a hurry, Roband conveyor toasters are the answer.

With the capacity to toast up to 500 slices per hour*, this toaster can handle the heaviest demands. Add the convenience of the front load/front return feature and you have an unbeatable combination.



FEATURES

- Stainless steel body
- Selectable heat source top or bottom or both together
- Front entry, adjustable front return or pass through exit chute
- Variable electronic conveyor speed control
- Cover for speed controller switch so guests don't alter setting
- Easy-clean crumb tray & reflector
- Dura-life stainless steel elements for prolonged element life



TCR15 pictured.
TCR10 looks identical.



SPECIFICATIONS

MODEL	SLICES/HR (up to)	POWER Watts	CURRENT Amps	DIMENSIONS w x d x h (mm)
TCR10	300*	2300	10.0	475 x 430 x 370
TCR15	500*	3220	14.0	475 x 430 x 370

*Variations may occur depending on voltage supply and bread product (see page 64).

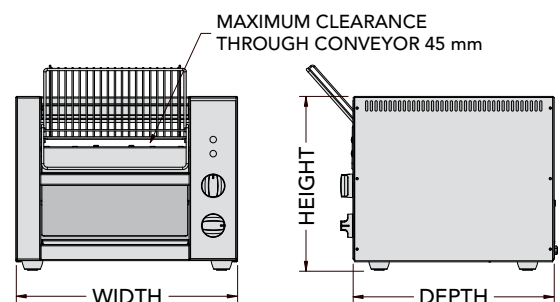

Eclipse Bun & Snack Toasters

Providing ultimate toasting control for back-of-house kitchen staff, the Eclipse is designed for high speed bun toasting and toasting of small bread based snack items. The machine provides precise and independent variable heat control of the top element and bottom element to enable users to produce the desired result on each side of their product.



FEATURES

- Modern brushed stainless steel construction
- Independent and precise variable control of top and bottom element heat output
- Solid State Electronics offer precise temperature control and greater component reliability, creating the exact toasting environment to suit many products
- Control of conveyor belt speed
- Two entry chutes providing different entry angles, standard wire 48° or stainless steel 25°
- Front return or pass through chute operation
- Adjustable angle on rear chute – 3 angles (10°, 17.5°, 25°)
- Dura-life stainless steel elements for prolonged element life
- Removable crumb trays for easy cleaning
- 40 mm entry chute clearance
- Maximum toasting diameter up to: return chute 130 mm, pass-through 310 mm



ET315 pictured.
ET310 looks identical.



ET315 showing front chute and rear chute at adjustable angles.
ET310 looks identical.

SPECIFICATIONS

MODEL	BREAD SLICES/HR (up to)	BUN HALVES/HR (up to)	POWER Watts	CURRENT Amps	DIMENSIONS w x d x h (mm)
ET310	300*	270*	2300	10.0	480 x 495 [^] x 400 [^]
ET315	500*	370*	3260	14.2	480 x 495 [^] x 400 [^]

*Variations may occur depending on voltage supply and bread product (see page 64).

[^]Depth and height does not include protruding racks/chutes.



ET315 showing rear pass through chute. ET310 looks identical.

Sycloid® Toasters

Elegantly designed and crafted, the revolutionary Sycloid® toaster sets a new standard for high speed toast production. The Sycloid's stylish exterior houses a cleverly engineered machine that provides truly functional energy efficient operation and an outstanding toasting result time after time.

 **sycloid®**
TOASTER



FEATURES

- Available in red, black or natural colours with the option of either 10 Amps producing over 350 slices per hour, or 13 Amps, producing over 500 slices per hour.
- All Sycloid toasters deliver excellent toasting results for bread up to 30 mm thickness. As most bread used in buffets is expected to be less than 20 mm thickness, the Sycloid is optimised to deliver its best result for bread of this thickness, but can accommodate slices up to 30 mm.
- Patron and staff safety is paramount and the Sycloid® toaster has been designed with “cool to touch” safe external touch temperatures and a lid locking latch.
- Intelligent energy efficient design – an automatic power-save mode conserves energy during quiet periods by scaling back energy consumption when in toast mode. The intelligent auto-sense feature detects when a new slice is placed in the machine and automatically prepares the machine to toast the bread. The heat setting in this mode is balanced and optimised to ensure quick recovery.
- A user-friendly and reliable speed controller allows adjustment of the toasting time to account for different types of bread to be toasted. The knob setting lock feature allows staff to set the toasting speed, removing the risk of patrons altering the setting.
- Diners can easily see when their toast is ready from across the buffet with the stylishly sculpted toast return chute with LED lighting that provides easy and illuminated viewing of the toast holding bay. The wide opening of the bay allows easy access to toast, which the radiant heat from the elements helps to keep warm.
- Featuring robust stainless steel elements, the Sycloid® toaster also features a modern brushed stainless steel exterior, perfect for disguising finger prints on a machine expected to be heavily used. It also includes a slide-out crumb tray for every-day cleaning and a hinged top cover allowing easy access to clean the inside.
- The Sycloid® toaster produces a beautiful toasting result throughout the entire slice of bread.



Sycloid® Toasters cont'd

The Hottest Toaster that's "Cool-to-Touch"

FEATURES



Also available in these colours:

	
Red	Black

Sycloid® Toasters cont'd

FEATURES

Toasting speed controller with electronic lock setting feature



Indicator light for auto-sensing feature



Removable crumb tray for ease of cleaning



Lid-lock release lever to lift lid



LED lights illuminate the toast holding bay

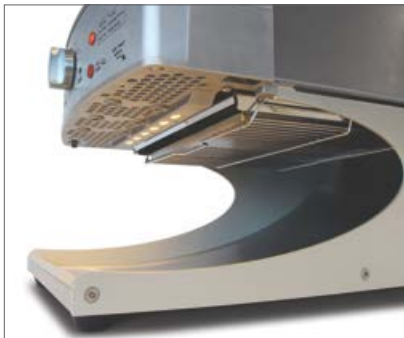

Hinged top cover for easy access to clean inside

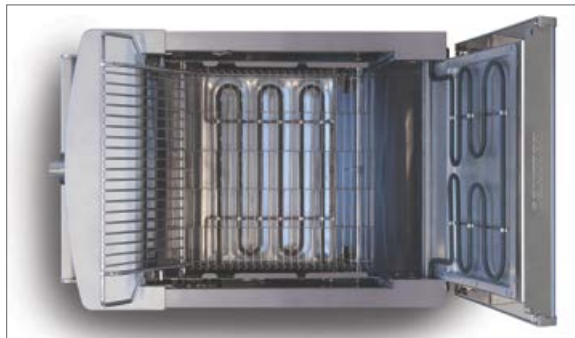

SPECIFICATIONS

MODEL	COLOUR	SLICES / HR (min)	CURRENT Amps	POWER Watts	DIMENSIONS W x D x H (mm)	WEIGHT Kg
ST350A	Natural	350	10.0	2300	412 x 596 x 421	25
ST350AR	Red	350	10.0	2300	412 x 596 x 421	25
ST350AB	Black	350	10.0	2300	412 x 596 x 421	25
ST500A	Natural	500	13.0	2990	412 x 596 x 421	25
ST500AR	Red	500	13.0	2990	412 x 596 x 421	25
ST500AB	Black	500	13.0	2990	412 x 596 x 421	25

DIMENSIONS

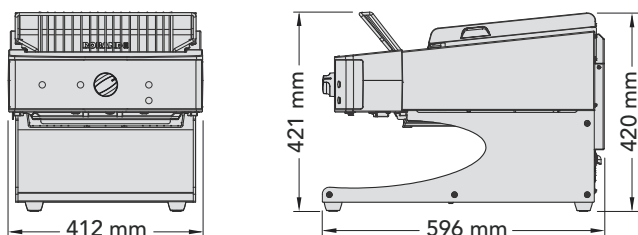

Vertical Toasters

These vertical toasters can accommodate up to six slices with a reduced slice selection switch for economy in quieter periods. Both models utilise an automatic element timer for consistent results. Once cooked, the toast can remain warm in the machine before being manually ejected. Designed for continuous use.



TC66 pictured

FEATURES

- Stainless steel construction
- 6 minute timer
- Easy-clean crumb tray
- Multi-slice selection
- Dura-life stainless steel elements for prolonged element life
- Slot width 2.8 cm by 14 cm

SPECIFICATIONS

MODEL	SLICES No.	POWER Watts	CURRENT Amps	DIMENSIONS w x d x h (mm)
TC55	5	2200	9.6	420 x 265 x 312
TC66	6	2570	11.2	420 x 265 x 312

Note: Unit designed for continuous use. A change in selection of the number of slices toasted will require a period for element temperatures to equalise. Uneven toasting may result during these transitional periods.

Salamander



The Roband Salamander is ideal for grilling, top toasting and finishing off ingredients such as cheese, mornays and toppings. Fast, economical and versatile, the Roband salamander will quickly become an integral part of your busy kitchen.



SA15 pictured

FEATURES

- Stainless steel construction
- Dual energy regulator control
- Dura-life stainless steel elements for prolonged element life
- Wall mount kit included
- Easy-clean crumb tray & reflector
- Powerful top only heating

SPECIFICATIONS

MODEL	SLICES No.	POWER Watts	CURRENT Amps	DIMENSIONS w x d x h (mm)	RACK DIMENSIONS w x d (mm)
SA15	15	3200	13.9	690 x 455* x 355	560 x 345^

*Depth does not include protruding rack. Including rack, depth is 495 mm.
 ^Depth doesn't include handle. Including handle depth is 490 mm.
 Maximum toasting height is 121 mm with toasting rack in lowest position.

Griddles

From the outside, all brands of Griddles look quite similar but, it's what's inside a Griddle that determines how well the machine will perform under pressure and when you need it the most.



This is where Roband Griddles are set apart from the competition and allow you to precisely cook a variety of food from steaks, chicken, fish and burger patties, fritters to eggs and bacon.

All Roband griddles feature uniquely designed elements that provide maximum temperature penetration specifically into the thick, steel griddle plate. The unique element design results in a smooth, controllable and even temperature across the cooking surface.

Roband Griddles help you achieve:

- 1) Faster cooking times with rapid temperature recovery when loaded with food
- 2) Lower power consumption and heat losses
- 3) Even temperatures for professional cooking
- 4) Reliable food quality outcomes

Three Griddles are offered in the Roband range, each delivering best in class performance. Every machine plate size has been engineered to deliver the best cooking experience possible from the power supplied.

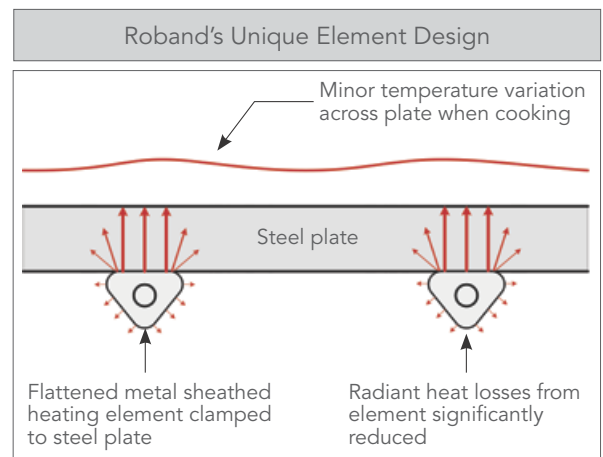

FEATURES

- 8 mm thick griddle plates for superior heat retention
- Superior, compacted griddle plate elements for fast temperature recovery and reliable temperature control
- Thermostat control for precise cooking temperature. Dual on G700 for control of left and right side of plate
- Large capacity forward positioned grease box which is dual skin for lower touch temperatures and integrated into machine to reduce risk of spillage and minimise bench space

Griddles cont'd

Griddle Selection Guide



G500 pictured



G500XP pictured



G700 pictured

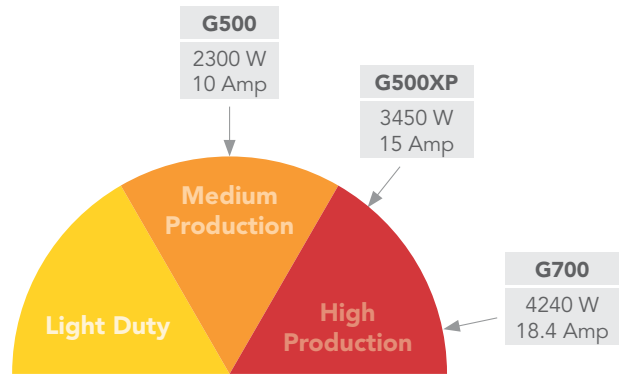

SPECIFICATIONS

MODEL	POWER Watts	CURRENT Amps	PHASE	DIMENSIONS ^ w x d x h (mm)	COOKING SURFACE w x d (mm)
G500	2300	10	1	538 x 443 x 263	515 x 340
G500XP	3450	15	1	538 x 443 x 263	515 x 340
G700*	4240	18.4	1 or 2 (+N)	725 x 529 x 263	700 x 400

*Installation must be carried out by a licensed electrician. For this reason, the G700 model does not come with a plug and cord. The decision on connection options should be made under consultation with your electrician. Can be wired for Single Phase or 2 phase + n. We recommend using more than 1 phase for this machine as multiple phases will help evenly balance load and will reduce stress on product components. ^Dimensions include grease box.

Griddle Toasters



Griddle Toasters are the perfect combination machine to produce a great top toasting result, whilst precisely cooking your steaks, eggs, bacon or hamburgers on the griddle cooking plate.

Each model within the Roband Griddle Toaster range has been engineered to maximise the performance of the machine in both the griddle and toasting functions.

They all feature separate elements for the heavy steel griddle plate as well as the toasting compartments to ensure consistent and optimal results across both functions.

Three Griddle Toaster models are available:

- 1) GT480 - honed to provide maximum punch from 10 Amps, caters to outlets that are limited by power supply, but still have a need for both griddle and top-toasting functions.
- 2) GT500 – slightly larger plate size than GT480 with more power and grunt. Designed for medium to fast paced food production.
- 3) GT700 - is for very busy operations with a need to produce significant volumes of food from a bench-top machine.

With a comprehensive, diverse and well-designed range of Griddle Toasters, a Roband solution can be found to suit almost any counter top application.

FEATURES:

- 8 mm thick steel cooking plates for superior heat retention (GT480 features 6 mm plate)
- Superior, compacted cooking plate elements for fast temperature recovery and reliable temperature control
- Thermostat control for precise griddle plate cooking temperature.
- Dual element system has independent control of the toasting function and griddle plate function, providing optimum cooking control for kitchen staff. The toasting compartment of all models is designed to work in tandem with the hotplate operation. (Note GT480 toast elements are controlled by the On/Off switch)
- The larger GT700 model features independent operation of the left or right side of the griddle and toaster for efficient use in quiet periods
- Large capacity forward positioned grease box which is dual skin for lower touch temperatures and integrated into machine to reduce risk of spillage and minimise bench space
- Toasting crumb tray is removable for easy cleaning of toasting compartment

Griddle Toasters cont'd



GT480 pictured



GT500 pictured



GT700 pictured

Griddle Toaster Selection Guide

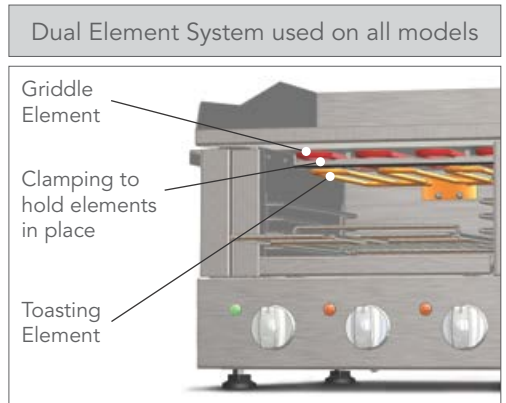
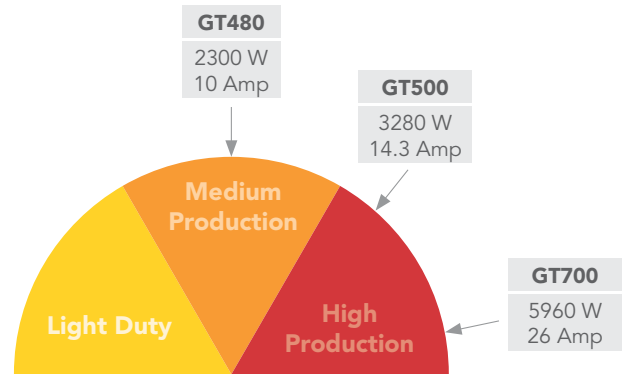

SPECIFICATIONS

MODEL	POWER Watts	CURRENT Amps	PHASE	DIMENSIONS [^] w x d x h (mm)	COOKING SURFACE w x d (mm)	MAX. FOOD CLEARANCE (mm)
GT480	2300	10.0	1	495 x 425 x 374	480 x 308	70
GT500	3280	14.3	1	537 x 457 x 374	515 x 340	70
GT700*	5960	26.0	1, 2 or 3 (+N)	725 x 541 x 374	700 x 400	70

*Installation must be carried out by a licensed electrician. For this reason, the GT700 model does not come with a plug and cord. The decision on connection options should be made under consultation with your electrician. Can be wired for Single Phase, 2 phase + n or 3 phase + n. We recommend using more than 1 phase for this machine as multiple phases will help evenly balance load and will reduce stress on product components. [^]Dimensions include grease box and do not include the protruding rack.

Double Skinned Hot Water Urns

Robatherm Hot Water Urns are stylishly finished and designed for commercial use. The Urns feature a unique mode selector switch that allows either variable or pre-set temperature control, providing ultimate flexibility and ease of use.

With the mode set to variable, the temperature can be controlled across a wide range via the graduated knob. Variable mode will suit those users who require warm or boiling water for their special application.

Switching the mode selector to pre-set will fix the temperature at 95 °C, the optimal temperature for most applications involving tea and coffee. Using pre-set mode offers a fast and easy setup, achieving consistent temperatures every time. Adjustment of the knob in pre-set mode has no effect on the temperature setting of the urn - it remains constant at nominal 95 °C. This prevents continuous boiling and excessive consumption of energy.



UDS10VP pictured



UDS20VP pictured

FEATURES

- Mode selector switch for either variable or pre-set 95 °C temperature control
- Available in 10, 20 or 30 litre sizes
- Double skinned tank construction for safe side temperatures, less than 50 °C
- Long life concealed elements allowing easy cleaning inside the urn
- Stylish brushed finish stainless steel exterior
- High grade 304 stainless steel inner tank
- Sturdy stainless steel non-drip tap
- Twist-lock lid with steam vent
- Sight-glass with cup capacity graduations
- Boil dry protection

Sturdy stainless steel non-drip tap



Double skin tank with concealed element



Variable or pre-set temperature functionality



SPECIFICATIONS

MODEL	CAPACITY* Cups (160 ml)	POWER Watts	CURRENT Amps	DIMENSIONS dia. x h (mm)
UDS10VP	50	2300	10.0	240 x 480
UDS20VP	120	2300	10.0	330 x 550
UDS30VP	160	2300	10.0	330 x 645

*Approximate capacity.

Percolator

The Robatherm Percolator, arguably best in its class, has been cleverly designed to deliver outstanding percolated coffee or tea in a simple to use fashion and with minimal parts to clean. Whilst the taste of the finished beverage speaks for itself, it's the elegant style, double skin construction with quality components such as a stainless steel tap, twist lock lid and sturdy handles coupled with the simple and effective coffee/tea basket design that sets this percolator apart from the competition.



FEATURES

- Double skin construction – reducing external touch temperatures
- Simplified and effective basket ensuring minimal parts to clean and preventing coffee granules or tea leaves from entering drink to be served
- Patented “safety dome” ensures a great tasting beverage and reduces risk of scalding if lid is inadvertently removed during percolation cycle
- Simple on/off operation – separate percolator element delivers coffee or tea whilst warming element keeps the beverage at serving temperature during and after percolation cycle
- Sturdy high-quality non-drip stainless steel tap
- 12.8 litre, 80 (160 ml) cup approximate capacity
- Twist lock lid with quality handles

SPECIFICATIONS

MODEL	CAPACITY* Litres / Cups (160 ml)	POWER Watts	CURRENT Amps	DIMENSIONS dia. x h (mm)
CP80	12.8 / 80	1650	7.2	270 x 500

*Approximate capacity.

The patented “safety dome” ensures great tasting coffee while also reducing the scalding risk.



Simple on/off operation



CP80 pictured

Frypod Counter Top Fryers

Breaking new ground with its innovative design, the Roband Frypod excels with its performance, safety and cleanliness of operation.

Delivering perfectly fried food time after time, the responsiveness of the Frypod elements to any drop in temperature has been honed and the temperature band that the fryer continues to operate in when loaded with food has been tightened.

This ensures that the temperature drop of the oil is minimised during the cooking process, delivering consistent, perfect results. It also means less oil in the food and longer oil life. With a modern brushed stainless steel finish, the sleek exterior also houses a simple but clever safety lock mechanism that prevents users from removing the elements when the machine is switched on and prevents the machine from being turned on when the elements are removed.



Smart safety lock mechanism prevents element removal when machine is on



Elements swing back and lock in place for element draining and tank removal



Bevelled fryer body providing a lip for easy tank removal



Single Pan Frypods

FEATURES

- Precise thermostat control
- Modern brushed stainless steel finish
- Splashguard with bash plate that returns oil to tank
- Safety lock mechanism prevents element removal when machine is on
- Elements swing back and lock in place for draining and tank removal
- Bevelled fryer body for easy tank removal
- Safety over-temperature cut-out
- Max & min oil level markers
- Element guard and capillary protection
- Multi-functional fryer lid included
- Isolating switch
- Insulated basket handle



FR15 pictured

SPECIFICATIONS

MODEL	TANK Litres	POWER Watts	CURRENT Amps	MACHINE DIMENSIONS [^] w x d x h (mm)	HEAT UP TIME, Mins (25 - 180 °C)	THAWED CHIPS PROD. Kg/Hr	FROZEN CHIPS PROD. Kg/Hr	BASKET SIZE* w x d x h (mm)
FR15	5	2300	10.0	290 x 480 x 335	11	7	6.5	215 x 215 x 137
FR18	8	3450	15.0	290 x 480 x 385	13	10.5	10	215 x 215 x 137

*All these models have the same basket chip capacity of 1 Kg. [^]Depth does not include protruding basket handle.

Single Pan/Double Basket Frypods

Double basket flexibility in a single pan fryer. Conserve counterspace and still retain the ability to prepare individual orders or to coordinate dishes with different cooking times.

FEATURES

- All the features of the single pan Frypods with double basket flexibility



FR111 pictured

SPECIFICATIONS

MODEL	TANK Litres	POWER Watts	CURRENT Amps	MACHINE DIMENSIONS [^] w x d x h (mm)	HEAT UP TIME, Mins (25 - 180 °C)	THAWED CHIPS PROD. Kg/Hr	FROZEN CHIPS PROD. Kg/Hr	BASKET SIZE* w x d x h (mm)
FR111	11	3450	15.0	555 x 480 x 335	18	14	12.5	215 x 215 x 137

*Basket chip capacity of 1 Kg. [^]Depth does not include protruding basket handles.

Double Pan Frypods

Featuring two pans and two baskets the choice is yours, double the quantities, stagger the orders or keep food separate.

FEATURES

- Precise thermostat control
- Modern brushed stainless steel finish
- Safety lock mechanism prevents element removal when the machine is on
- Elements swing back and lock in place for draining and tank removal
- Bevelled fryer body for easy tank removal
- Splashguards with bash plate that returns oil to tank
- Multi-functional fryer lids included
- Safety over-temperature cut-out
- Max & min oil level markers
- Element guard and capillary protection
- Insulated basket handles
- Isolating switch



FR28 pictured with pan covers



FR25 pictured

SPECIFICATIONS

MODEL	TANK Litres	POWER Watts	CURRENT Amps	MACHINE DIMENSIONS [^] w x d x h (mm)	HEAT UP TIME, Mins (25 - 180 °C)	THAWED CHIPS PROD. Kg/Hr	FROZEN CHIPS PROD. Kg/Hr	BASKET SIZE* w x d x h (mm)
FR25	2 x 5	2 x 2300	2 x 10.0	570 x 480 x 335	11	14	13	215 x 215 x 137
FR28	2 x 8	2 x 3450	2 x 15.0	570 x 480 x 385	13	21	20	215 x 215 x 137

*All these models have the same basket chip capacity of 1 Kg. [^]Depth does not include protruding basket handles.

F Series Single Pan Fryers



Counter top frying at its simplest, with all the power and efficiency of the larger models, your Roband single pan fryer will provide high performance whilst freeing up valuable counter top space.



F15 pictured with pan cover

FEATURES

- Stainless steel construction
- Precise thermostat control
- Swing back element
- Maximum & minimum oil level markers
- Easily removable tank
- Isolating switch
- Insulated basket handle
- Element guard & capillary protection
- Safety over-temp cut-out
- Pan cover included

SPECIFICATIONS

MODEL	TANK Litres	POWER Watts	CURRENT Amps	MACHINE DIMENSIONS ^ w x d x h (mm)	HEAT UP TIME, Mins (25 - 180 °C)	THAWED CHIPS PROD. Kg/Hr	FROZEN CHIPS PROD. Kg/Hr	BASKET SIZE* w x d x h (mm)
F15	5	2300	10.0	275 x 425 x 340	11	7	6.5	215 x 215 x 137
F18	8	3450	15.0	275 x 425 x 390	13	10.5	10	215 x 215 x 137

*All these models have the same basket chip capacity of 1 Kg. ^Depth does not include protruding basket handle.

F Series Single Pan/Double Basket Fryers

Double basket flexibility in a single pan fryer. Conserve counterspace and still retain the ability to prepare individual orders or to coordinate dishes with different cooking times.

FEATURES

- All the features of the single pan fryer with double basket flexibility



F111 pictured

SPECIFICATIONS

MODEL	TANK Litres	POWER Watts	CURRENT Amps	MACHINE DIMENSIONS ^ w x d x h (mm)	HEAT UP TIME, Mins (25 - 180 °C)	THAWED CHIPS PROD. Kg/Hr	FROZEN CHIPS PROD. Kg/Hr	BASKET SIZE* w x d x h (mm)
F111	11	3450	15.0	545 x 425 x 340	18	14	12.5	215 x 215 x 137

*Basket chip capacity: F111 = 1 Kg. ^Depth does not include protruding basket handles.

F Series Double Pan Fryers

With two pans and two baskets the choice is yours. Double the quantities, stagger the orders or keep food separate. Whatever the purpose, the Roband double pan fryers will open up the options.

FEATURES

- Stainless steel construction
- Precise thermostat control
- Swing back element
- Maximum & minimum oil level markers
- Safety over-temp cut-out
- Isolating switch
- Insulated basket handles
- Element guard & capillary protection
- Easily removable tank
- Pan covers included



F25 pictured

SPECIFICATIONS

MODEL	TANK Litres	POWER Watts	CURRENT Amps	MACHINE DIMENSIONS [^] w x d x h (mm)	HEAT UP TIME, Mins (25 - 180 °C)	THAWED CHIPS PROD. Kg/Hr	FROZEN CHIPS PROD. Kg/Hr	BASKET SIZE* w x d x h (mm)
F25	2 x 5	2 x 2300	2 x 10.0	545 x 425 x 340	11	14	13	215 x 215 x 137
F28	2 x 8	2 x 3450	2 x 15.0	545 x 425 x 390	13	21	20	215 x 215 x 137

*All these models have the same basket chip capacity of 1 Kg. [^]Depth does not include protruding basket handles.

Donut Fryer

Produce perfect donuts every time. Designed specifically for donut frying, the shallow pan ensures optimum temperatures and recovery times for perfect results.

FEATURES

- Safety over-temp cut-out
- Isolating switch
- Swing back element
- Element guard
- Precise thermostat control
- Side trays, racks and lifters included
- Stainless steel construction



FD10 pictured

SPECIFICATIONS

MODEL	TANK Litres	POWER Watts	CURRENT Amps	MACHINE DIMENSIONS [^] w x d x h (mm)	HEAT UP TIME Mins (25 - 180 °C)	RACK SIZE w x d (mm)
FD10	8.5	2300	10.0	380 x 485 x 290	20	340 x 295

[^]Depth does not include protruding basket handle.

Pie Master Pie & Food Warmers



PM50L pictured

The newly designed, attractive and functional Pie Masters display food at the desired serving temperature. With a variety of sizes and options available, they set the standard for display of pies, sausage rolls and other pastry based hot foods.

Three sizes are available with capacity for 25, 50 or 100 pies. They all feature a modern, brushed stainless steel body with adjustable feet and metal control knobs. Racks can be installed horizontally or at an angle to enable contents to be displayed in the most appealing way.

“L” models feature an internal light to illuminate food as well as a steam pan seated in a baffle tray to produce a delicate steam to keep food moist.

FEATURES

- Stylish brushed stainless design
- Variety of sizes available - 25, 50 and 100 pie capacity
- Adjustable feet
- Easily removable crumb tray
- Display racks in each unit can be positioned horizontally or at an angle enabling the best display of contents.
- Stop rail on each shelf so food does not touch the glass
- Sliding glass door variations (50 & 100 pie capacity models). Hinged glass door (25 pie capacity models)

ADDITIONAL FEATURES - RANGE WITH LIGHTS

- Baffle tray with steam (1/9 gastronorm) pan in the base of the unit to provide moisture to contents
- Internal light to illuminate contents



PM25 pictured

SPECIFICATIONS

MODEL	PIE CAPACITY	DOORS	INTERNAL LIGHT	POWER Watts	CURRENT Amps	DIMENSIONS ^ w x d x h (mm)
PM25	25	Hinged glass door	No	1100	4.8	401 x 398 x 585
PM25L	25	Hinged glass door	Yes	1200	5.2	401 x 398 x 585
PM50	50	Glass doors single side	No	1250	5.4	610 x 392 x 507
PM50G	50	Glass doors both sides	No	1250	5.4	610 x 392 x 507
PM50L	50	Glass doors single side	Yes	1350	5.9	610 x 392 x 507
PM50LG	50	Glass doors both sides	Yes	1350	5.9	610 x 392 x 507
PM100	100	Glass doors single side	No	1550	6.7	772 x 392 x 587
PM100G	100	Glass doors both sides	No	1550	6.7	772 x 392 x 587
PM100L	100	Glass doors single side	Yes	1650	7.2	772 x 392 x 587
PM100LG	100	Glass doors both sides	Yes	1650	7.2	772 x 392 x 587

Models With Lights Available Mid 2020

Pie Warmer & Merchandiser

Introducing the Roband pie warmer that knows how to sell. Maximise your returns with the Roband PM60. Better display means greater turnover, fresher products, greater profits.

FEATURES

- Attractively displays pies
- Angled racking system for better display
- Illuminated advertising space in top light box
- Stylish design
- 60 pie capacity
- Glass on all four sides
- Sliding glass doors front and rear (G model)
- Black powder coated body
- Fluorescent lighting
- 10 Amp plug



PM60G pictured

SPECIFICATIONS

MODEL	PIE CAPACITY (Approx.)	POWER Watts	CURRENT Amps	DIMENSIONS w x d x h (mm)
PM60	60	1568	6.8	655 x 490 x 670
PM60G*	60	1568	6.8	655 x 490 x 670

*G indicates glass doors both sides.

Hammertone Finish Pie Warmers

Finished in silver hammertone on a steel body, all units have thermostat control, thermometer and removable crumb trays. Models 40DT and 80DT have removable drawers with stainless steel fronts and are designed for pies, pastries and sausage rolls. The 83DT has sliding steel doors, three removable wire shelves and is designed for pies and food containers. Roband pie warmers are ideal for lunch rooms, canteens and construction sites.

FEATURES

- Precise thermostat control
- Easily removable shelves, doors, drawers and crumb tray for easy cleaning
- Double skin cavity for even temperature and low running costs
- Thermometer
- Single phase 10 Amp plug



40DT pictured



83DT pictured

SPECIFICATIONS

MODEL	DESCRIPTION	PIE CAPACITY (Approx.)	POWER Watts	CURRENT Amps	DIMENSIONS w x d x h (mm)
40DT	Removable drawers	40	1250	5.4	505 x 320 x 360
80DT	Removable drawers	80	1250	5.4	585 x 350 x 485
83DT	Sliding steel doors	40	1250	5.4	585 x 350 x 485

Carving Station

Roband carving stations are the ideal solution for cafes, clubs and restaurants to keep roasted meat warm, illuminated and moist prior to serving.

Heat from above and below combines with steam from the pan to deliver moisture and heat. The perforated and spiked pan keeps the meat secure for carving, whilst the larger pan sitting underneath contains the water to produce steam and collects any fat drippings.

FEATURES

- Heat source from above and below
- Energy regulator control of element (heating from below)
- Crumb/drip tray
- Full size pan (65 mm deep) with full size perforated and spiked pan (25 mm deep)
- Maximum pan depth 65 mm
- Adjustable feet
- Stainless steel construction

SPECIFICATIONS

MODEL	POWER Watts	CURRENT Amps	DIMENSIONS w x d x h (mm)
CS10	1750	7.6	355 x 650 x 570



CS10 pictured

Chip Warmer

Enhance productivity and presentation by creating an area to hold, serve and display cooked chips. Heating from above and below, the Roband chip warmer maintains cooked chips at the correct serving temperature and allows the basket to be immediately returned to the fryer for the next batch. At the same time, the heat lamps serve to throw a yellow light onto the cooked chips to enhance presentation.

FEATURES

- Heat source from above and below
- Sloped tray for ease of serving
- Energy regulator control
- Stainless steel body
- Adjustable feet

SPECIFICATIONS

MODEL	POWER Watts	CURRENT Amps	DIMENSIONS w x d x h (mm)
CW10	1750	7.6	710 x 590 x 605



CW10 pictured

Multi-Function Chip & Food Warmer

MW10 - Base unit shown with optional 1/1 gastronorm pan 100 mm deep (sold separately) pictured with light on



MW10CW - Chip Warmer pictured with light on



MW10CS - Carving Station pictured with light on



The multi-function food and chip warmer is a compact bench-top warmer that can accommodate a range of accessories to suit the type of hot food being displayed. With heat source from above (quartz heat lamp) and from below (stainless steel elements), the unit attractively holds and displays hot food, ready for service.

MW10 – Base Unit

The MW10 is supplied without any accessories or trays. It can accommodate a range of gastronorm pan configurations to suit the specific hot food being displayed. Combinations of pans up to a full sized 1/1 (100 mm deep) gastronorm pan can be accommodated. With heat from above and below, the MW10 can hold cooked food at correct serving temperature whilst being appealingly displayed.

MW10CW – Chip Warmer

Supplied with a sloping tray for chips, the MW10CW is designed to enhance productivity and presentation of cooked chips. Heating from above and below, the unit maintains cooked chips at the correct serving temperature and allows the fryer basket to be immediately returned to the fryer for the next batch, increasing fryer productivity. At the same time, the heat lamp serves to throw heat and a yellow light onto the cooked chips to enhance presentation.

MW10CS – Carving Station

The MW10CS is supplied with a full size (65 mm deep) gastronorm pan with a full size perforated and spiked pan (25 mm deep) so that the unit can be used as a carving tray. The perforated and spiked tray secures the meat for easy carving, whilst the larger pan sitting underneath holds water to produce steam and keep the meat moist and collects any fat drippings. The heat lamp throws a warm yellow light over the meat to enhance presentation.

FEATURES

- Halogen Heat lamp
- Heat source from above (Easy Fit heat lamp) and below (stainless steel element)
- Energy regulator control of element (heating from below)
- Ultra-durable stainless steel element

SPECIFICATIONS

MODEL	DESCRIPTION	POWER Watts	CURRENT Amps	DIMENSIONS w x d x h (mm)
MW10	Multi-function base unit fits 1/1 gastronorm pan (not included)	685	3.0	395 x 640 x 475
MW10CW	Multi-function Chip Warmer with sloped tray for chips	685	3.0	395 x 640 x 475
MW10CS	Multi-function Carving Station with 1/1 size 25 mm deep perforated & spiked carving pan and 1/1 size 65 mm deep pan underneath	685	3.0	395 x 640 x 475

Boiling Hot Plates

Portable power at its best. Whether you are on the move or simply need additional power in the kitchen, Roband boiling plates are the ideal solution. Totally portable, these units have the power and versatility to simmer, boil or fry in any location.



12 pictured

FEATURES

- Six heat settings for each hot plate
- High speed recovery
- Sealed cast iron hot plates
- Stainless steel construction



13 pictured

SPECIFICATIONS

MODEL	POWER Watts	CURRENT Amps	DIMENSIONS w x d x h (mm)	HOT PLATE DIAMETER (mm)
11	1840	8.3	300 x 255 x 105	1 x 190
12	2300	10.0	510 x 265 x 105	2 x 150
13	1840	8.3	360 x 282 x 105	1 x 230

Coffee Warmer



The Roband coffee warmer will keep two pots of hot coffee at the correct serving temperature without allowing the coffee to be spoilt through boiling.

FEATURES

- Stainless steel body
- Two illuminated on/off switches
- Attractive enamelled plates



KH2 pictured

SPECIFICATIONS

MODEL	POWER Watts	CURRENT Amps	DIMENSIONS w x d x h (mm)
KH2	250	1.1	385 x 220 x 75

Pasta Master/Vegetable Blancher

From fridge to table in moments. The Roband pasta master will return pre-prepared pasta dishes such as spaghetti, fettuccine and tortellini to serving temperature quickly and efficiently. This machine can also be used for blanching vegetables.



MP18 pictured

FEATURES

- 18/10 Stainless steel construction
- Precise thermostat control 30-120 °C
- Easily removable tank
- Swing back element
- Stainless steel fine mesh baskets
- Pan cover included

SPECIFICATIONS

MODEL	TANK Litres	POWER Watts	CURRENT Amps	DIMENSIONS w x d x h (mm)	BASKET SIZE* w x d x h (mm)
MP18	8	2240	9.7	275 x 425 x 340	100 x 215 x 145

*2 x baskets.

Hot Dog & Bun Warmers

Treat your customers to delicious, steaming hot dogs, with the Roband hot dog and bun warmer. The see-through glass tank presents the hot dogs appealingly and the models with spikes heat the buns for a perfect combination.

FEATURES

- Stainless steel construction
- Energy regulator controls
- Heated aluminium spikes
- Optional Teflon® coated spikes
- Tank divider to separate heating and cooked product
- Available without spikes, model M1
- Available without steam tank, model M6T



M3 pictured



M1 pictured



M6T pictured

SPECIFICATIONS

MODEL	SPIKES	STEAM TANK	TEFLON® COATED	POWER Watts	CURRENT Amps	DIMENSIONS w x d x h (mm)
M1	0	YES	NO	700	3.0	350 x 270 x 300
M3	3	YES	NO	1000	4.4	350 x 350 x 300
M3T	3	YES	YES	1000	4.4	350 x 350 x 300
M6T	6	NO	YES	600	2.6	355 x 240 x 300

Quartz Heat Lamp Assemblies



The stylish and functional Roband quartz heat lamp assemblies provide a balance of heat and light to front or back of house applications. They are manufactured from extruded anodised aluminium, with a number of different sizes and options available to suit various requirements. All models come with a standard mount bracket. Optional mount kit is also available. See page 40 for details.

Designed by Roband Australia, Easy Fit Globes feature a protective quartz outer layer that encapsulates the inner globe allowing for easier handling. This secondary layer of glass also protects food from globe breakages by capturing the shards and eliminating the need for a traditional glass window in the base of the cover. Lamp replacement can now be performed without the need for an electrician and takes only seconds.

Standard Models

The standard heat lamp assemblies (e.g. HQ450E) come **with** a control box that houses the isolating on/off switch. They also feature a simple mounting system and come complete with a 10 Amp plug and cord.

Fabricator Models

The heat lamp assemblies are also available **without** the control box and on/off switch (e.g. HUQ375E) so they can be connected to a remote switch setup. The removal of the control box shortens the length of the lamp assembly accordingly.

Standard mounting bracket available on standard and fabricator models



Quartz Heat Lamp Assemblies cont'd

SPECIFICATIONS - STANDARD MODELS (INCLUDES CONTROL BOX)

MODEL	INTERNAL LAMPS	MOUNT TYPE	CURRENT Amps	POWER Watts	LENGTH mm	LAMP CENTRES*	INCLUSIONS
HQ450E	1 lamp	Standard	1.5	350	450	N/A	Switch, plug & cord
HQ900E	2 lamps	Standard	3.0	700	900	400	Switch, plug & cord
HQ1200E	3 lamps	Standard	4.6	1050	1200	345	Switch, plug & cord
HQ1500E	4 lamps	Standard	6.1	1400	1500	345	Switch, plug & cord
HQ1800E	4 lamps	Standard	6.1	1400	1800	400	Switch, plug & cord
HQ2100E	5 lamps	Standard	7.6	1750	2100	400	Switch, plug & cord

*Length between centre of each lamp.



HQ1200E pictured

SPECIFICATIONS - FABRICATOR MODELS (NO CONTROL BOX)

MODEL	INTERNAL LAMPS	MOUNT TYPE	CURRENT Amps	POWER Watts	LENGTH mm	LAMP CENTRES*	INCLUSIONS
COMPLETE WITH A, N & E WIRE IN PTFE 1700 MM LENGTH FOR INSTALLATION TO YOUR OWN CONTROLLER							
HUQ375E	1 lamp	Standard	1.5	350	375	N/A	N/A
HUQ825E	2 lamps	Standard	3.0	700	825	400	N/A
HUQ1125E	3 lamps	Standard	4.6	1050	1125	345	N/A
HUQ1425E	4 lamps	Standard	6.1	1400	1425	345	N/A
HUQ1725E	4 lamps	Standard	6.1	1400	1725	400	N/A
HUQ2025E	5 lamps	Standard	7.6	1750	2025	400	N/A

*Length between centre of each lamp.



HUQ1125E pictured

Showing wire guard open for easy replacement of the globe



Dimensions for all standard quartz and fabricator quartz lamps (HQ & HUQ models). Brackets are removable.

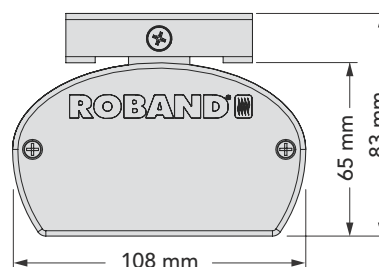

Infra-Red Heating Assemblies



Roband infra-red heating assemblies are manufactured from an extruded anodized aluminium section, specifically designed to breathe. These units are designed for use at either front or back of house where more heat and no light is required. The heat is provided by a stainless steel element and an energy regulator is used on the standard units to precisely control the output, emitting a very even heat over the length of the warming area. All models come with a standard mount bracket. Optional mount kit is also available. See page 40 for details.

Standard Models

The standard infra-red heating assemblies (e.g. HE900) come **with** a control box that houses the isolating on/off switch and an energy regulator to control heat output. They also feature a simple mounting system and come complete with a 10 Amp plug and cord.

Fabricator Models

The infra-red heating assemblies are also available **without** the control box, energy regulator and on/off switch (e.g. HUE825) so they can be connected to a remote switch setup. The removal of the control box shortens the length of the assembly accordingly.

Standard mounting bracket available on standard and fabricator models



A variable control energy regulator is used to precisely control the output



Infra-Red Heating Assemblies cont'd

SPECIFICATIONS - STANDARD MODELS (INCLUDES CONTROL BOX)

MODEL	DESCRIPTION	MOUNT TYPE	CURRENT Amps	POWER Watts	LENGTH mm	INCLUSIONS
HE900	1 element	Standard	3.9	900	900	Switch, plug & cord
HE1200	1 element	Standard	5.2	1200	1200	Switch, plug & cord
HE1500	1 element	Standard	6.5	1500	1500	Switch, plug & cord
HE1800	1 element	Standard	7.8	1800	1800	Switch, plug & cord



HE1200 pictured

SPECIFICATIONS - FABRICATOR MODELS (NO CONTROL BOX)

MODEL	DESCRIPTION	MOUNT TYPE	CURRENT Amps	POWER Watts	LENGTH mm	INCLUSIONS
COMPLETE WITH A, N & E WIRE IN PTFE 1700 MM LENGTH FOR INSTALLATION TO YOUR OWN CONTROLLER						
HUE825	1 element	Standard	3.9	900	825	N/A
HUE1125	1 element	Standard	5.2	1200	1125	N/A
HUE1425	1 element	Standard	6.5	1500	1425	N/A
HUE1725	1 element	Standard	7.8	1800	1725	N/A



HUE1125 pictured

Dimensions for standard infra-red heating assemblies (HE models). Brackets are removable.

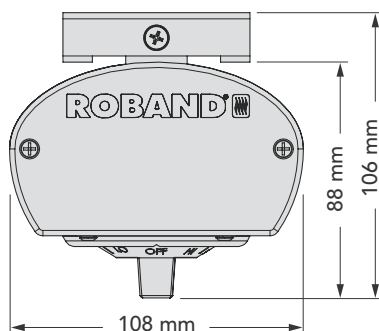

Dimensions for fabricator infra-red heating assemblies (HUE models). Brackets are removable.

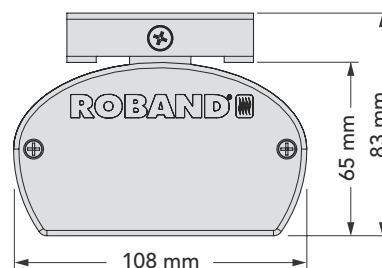

Fluorescent Lighting Assemblies

Roband fluorescent lamp assembly profiles match the aluminium extrusion from which the quartz lamp assemblies are manufactured.

Specifically designed for use in refrigerated displays or where illumination is required without heat, these units have a diffused perspex cover over the light. They also feature a simple mounting system and come complete with an isolating switch and a 10 Amp plug and cord.



HF900 pictured

SPECIFICATIONS

MODEL	DESCRIPTION	POWER Watts	CURRENT Amps	LENGTH mm
HF900	1 fluorescent globe	30	0.1	900
HF1500	1 fluorescent globe	45	0.2	1500

Dimensions for all fluorescent lighting assemblies (HF models). Brackets are removable.

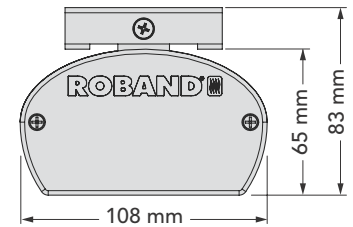

Optional Mount Kit

Mount kit for Quartz, Infra-red series & Fluorescent assemblies. The kit includes 2 x 19 mm diameter round tubes, inserts and mounting brackets, with instructions for installation by an electrician. 600 mm tubes can be cut to the desired length.



HM600 pictured

SPECIFICATIONS

MODEL	DESCRIPTION	MOUNT TYPE	LENGTH (mm)
HM600	Mount kit for all Quartz lamps, Infra-red heat assemblies & Fluorescent assemblies.	Round	600



Fabricator model with HM600 mount kit installed and shortened to the desired length

Heat Lamp Stands



Available in two sizes, the portable Roband Heat Lamp Stands are designed to hold Roband Quartz Lamp or Infra-red Heating Assemblies at an ideal height above the bench.

FEATURES

- Two sizes available to suit 900 & 1200 mm length Roband Heat or Illumination Assemblies
- Robust stainless steel construction
- Adjustable feet to level on uneven surfaces
- Stylish industrial design
- Quartz and Infra-red Assemblies sold separately
- Lamps positioned 350 mm above the base



HLS935 pictured



HLS1235 pictured

SPECIFICATIONS

STAND MODEL	DIMENSIONS w x d x h (mm)	WEIGHT Kg	SUITS QUARTZ & INFRA-RED ASSEMBLY MODELS*	DIMENSIONS Length (mm)	POWER Watts	CURRENT Amps
HLS935	1040 x 352 x 437 mm	5	HQ900E	900	700	3
			HE900	900	900	3.9
HLS1235	1340 x 352 x 437 mm	6	HQ1200E	1200	1050	4.6
			HE1200	1200	1200	5.2

*Sold separately.

Modular Heat Lamp

The HL350 is a compact modular designed heat lamp manufactured from stainless steel, incorporating an easy fit 230 volt, 350 watt globe. The easy fit globes feature a protective quartz glass outer layer that encapsulates the inner globe allowing for safe handling. It is designed for use in custom fabricated installations as a modular component to be wired in parallel.

SPECIFICATIONS

MODEL	DESCRIPTION	VOLTS	POWER Watts
COMPLETE WITH 300 MM PTFE FLYING LEADS (A + N) FOR INSTALLATION			
HL350	Modular lamp, single globe	230	350



HL350 pictured

DIMENSIONS

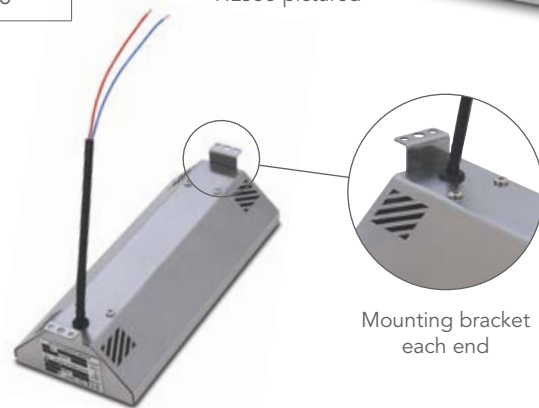
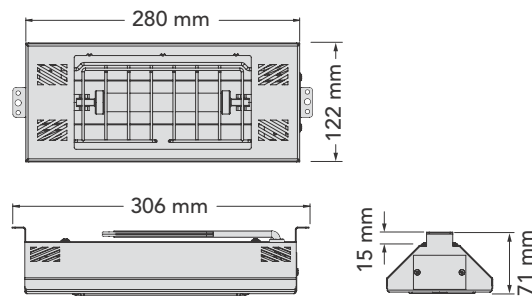

Mounting bracket each end

Individual Heat Lamps

These units are effective for overhead heating in food preparation and serving areas. Designed specifically to be wired in pairs and in series, Roband heat lamps maintain prepared food at the correct serving temperature, while enhancing presentation at the same time.

FEATURES

- Stainless steel construction
- Long life globes
- Series wiring further extends globe life
- Easily replaceable globes
- Aesthetic cover design

SPECIFICATIONS

	MODEL	DESCRIPTION	POWER Watts*	CURRENT Amps	DIMENSIONS w x d x h (mm)
A	HL22 [†]	500 W lamp only	250 [†]	1.1	190 x 120 x 50
	HL24 [†]	1000 W lamp only	500 [†]	2.2	270 x 120 x 50
	HL26 [†]	1500 W lamp only	750 [†]	3.3	335 x 120 x 50
B	HL22C [†]	HL22 with cover	250 [†]	1.1	270 x 120 x 80
	HL24C [†]	HL24 with cover	500 [†]	2.2	270 x 120 x 80
	HL26C [†]	HL26 with cover	750 [†]	3.3	335 x 120 x 80
C	HLC190	Cover to suit HL22	N/A	N/A	270 x 120 x 55
	HLC260	Cover to suit HL24	N/A	N/A	270 x 120 x 55
	HLC330	Cover to suit HL26	N/A	N/A	335 x 120 x 55

[†]Must be installed in pairs and wired in series. *Total power output of 1 pair wired in series.

HL26 x 2 pictured



A

HL26C x 2 pictured



B

HLC330 x 2 pictured

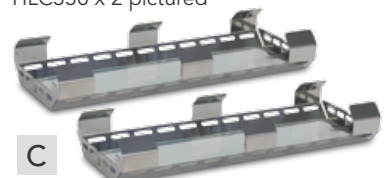

C

Your Business is our Business ...



The common law of business balance

"There is hardly anything in the world that someone cannot make a little worse and sell a little cheaper, and the people who consider price alone are that person's lawful prey.

It's unwise to pay too much, but it's worse to pay too little. When you pay too much, you lose a little money - that is all. When you pay too little, you sometimes lose everything, because the thing you bought was incapable of doing the thing it was bought to do.

The common law of business balance prohibits paying a little and getting a lot - it can't be done. If you deal with the lowest bidder, it is well to add something for the risk you run, and if you do that you will have enough to pay for something better."

John Ruskin (1819-1900)

Roband | Built to Last

Counter Top Bain Maries



Hold food at serving temperature with the convenience and style of a Roband counter top bain marie. With a comprehensive range of sizes and pan combinations, there is a counter top unit to suit every situation.

There are 4 configurations available. The options suit either 1 x 1/2 size pan, 2 x 1/2 size pans sitting either side to side (wide) or front to back (narrow) and 4 x 1/2 size pan configuration. Each option can accommodate a variety of different sized pans as shown in the Specifications table.

Heat control is either delivered by an energy regulator or thermostat. Thermostatically controlled machines end with the model suffix 'T'.

FEATURES

- Stainless steel construction
- Dura-life stainless steel elements for prolonged element life
- Slimline thermometer
- Designed to take many combinations of gastronorm pans up to 150 mm deep
- Removable cross bar on BM4 model range only
- 1, 2 or 4 pan models available. 2 pan configuration available in narrow or wide footprint
- Safety lock ball valve drain on BM2, BM21 and BM4 models
- Double skin tank

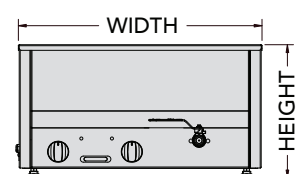
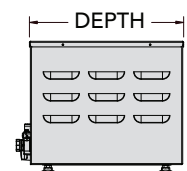

Refer to table on right hand page for model dimensions.



BM1A pictured



BM4E pictured



BM2B pictured.
(wide footprint)



BM21 pictured.
(narrow footprint)

SPECIFICATIONS

MODEL	DESCRIPTION/ INCLUSIONS	ENERGY REG/ THERMOSTAT Control	OPERATION ^		POWER Watts	CURRENT Amps	DIMENSIONS* w x d x h (mm)
			Wet	Dry			
1 x 1/2 SIZE PAN CONFIGURATION							
BM1	Pan not included	Energy reg	Yes	No	670	2.9	355 x 305 x 320
BM1A	1 x 1/2 size 100 mm pan & lid	Energy reg	Yes	No	670	2.9	355 x 305 x 320
BM1B	1 x 1/2 size 150 mm pan & lid	Energy reg	Yes	No	670	2.9	355 x 305 x 320
BM1E	1 x 200 mm round (7.25 L) pot & lid	Energy reg	Yes	No	670	2.9	355 x 305 x 320
BM1T	Thermostat control, pan not included	Thermostat	Yes	No	670	2.9	355 x 305 x 320
2 x 1/2 SIZE PANS CONFIGURATION - WIDE (2 Pans Wide x 1 Pan Deep)							
BM2	Pans not included	Energy reg	Yes	Yes	1000	4.4	560 x 355 x 320
BM2A	2 x 1/2 size 100 mm pans & lids	Energy reg	Yes	Yes	1000	4.4	560 x 355 x 320
BM2B	3 x 1/3 size 100 mm pans & lids	Energy reg	Yes	Yes	1000	4.4	560 x 355 x 320
BM2C	3 x 1/3 size 150 mm pans & lids	Energy reg	Yes	Yes	1000	4.4	560 x 355 x 320
BM2E	2 x 200 mm round (7.25 L) pots & lids	Energy reg	Yes	Yes	1000	4.4	560 x 355 x 320
BM2T	Thermostat control, pans not included	Thermostat	Yes	No	1000	4.4	560 x 355 x 320
2 x 1/2 SIZE PANS CONFIGURATION - NARROW (1 Pan Wide x 2 Pans Deep)							
BM21	Pans not included, fits 2 x 1/2 size pans	Energy reg	Yes	Yes	1000	4.4	355 x 560 x 320
BM21T	BM21 with thermostat control 30 - 120 °C	Thermostat	Yes	No	1000	4.4	355 x 560 x 320
4 x 1/2 SIZE PANS CONFIGURATION							
BM4	Pans not included	Energy reg	Yes	Yes	1200	5.2	680 x 560 x 320
BM4A	4 x 1/2 size 100 mm pans & lids	Energy reg	Yes	Yes	1200	5.2	680 x 560 x 320
BM4B	6 x 1/3 size 100 mm pans & lids	Energy reg	Yes	Yes	1200	5.2	680 x 560 x 320
BM4C	6 x 1/3 size 150 mm pans & lids	Energy reg	Yes	Yes	1200	5.2	680 x 560 x 320
BM4E	4 x 200 mm round (7.25 L) pots & lids	Energy reg	Yes	Yes	1200	5.2	680 x 560 x 320
BM4T	Thermostat control, pans not included	Thermostat	Yes	No	1200	5.2	680 x 560 x 320

Note: Maximum pan depth 150 mm on all models.

^Machines should not be left unattended. *Heights exclude pans, pots and lids.

Sauce Warmer

With its 2 litre capacity, this versatile little unit excels when the quantities or location don't justify the use of a full size bain marie.

FEATURES

- Versatile - keeps sauces and gravies warm
- Portable compact design makes it ideal for small or off-site functions
- Easy to clean with a removable stainless steel 1/6 size pan
- 2 litre pan holds between 20 and 30 servings of gravy or sauce
- Dry operation only

SPECIFICATIONS

MODEL	POWER Watts	PAN CAPACITY	CURRENT Amps
MH16	125	1 x 1/6 size 150 mm plus lid	0.5



MH16 pictured

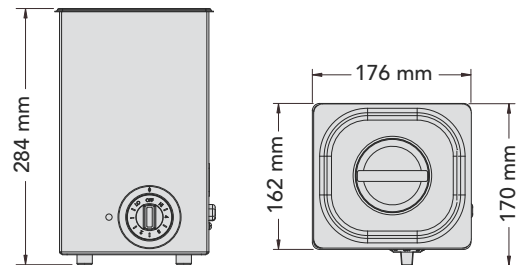

Chocolate Bain Maries

Designed for holding the temperature of melted chocolate for food coating applications.

FEATURES

- Designed to take various combinations of gastronorm pans
- Wet operation only ^
- Self-resetting thermal safety cut-out
- Double skin tank
- Thermostatically controlled (temperature range 20 - 50 °C)
- Stainless steel construction

^ Machines should not be left unattended.

SPECIFICATIONS

MODEL	POWER Watts	PAN COMBINATION	CURRENT Amps	DIMENSIONS w x d x h (mm)
CHOC1A	670	1 x 1/2 size 150 mm plus lid	2.9	355 x 305 x 320
CHOC2A	1000	2 x 1/2 size 150 mm plus lids	4.4	560 x 355 x 320

Note: Available without pans. Delete "A" from Model No.



CHOC2A pictured

Hot or Refrigerated Bain Maries

This range of bain maries is designed to hold food at serving temperature. Available as either hot or refrigerated units.

FEATURES - HOT & REFRIGERATED

- All stainless steel construction with tubular frame
- Removable cross bars
- Safety lock ball valve drain
- Trolleys available, see page 55

FEATURES - HOT

- Wet or dry operation ^
- Dura-life stainless steel elements for prolonged element life
- Energy regulator control
- Designed to take many combinations of gastronorm pans up to 100 mm deep
- Thermometer display

^ Machines should not be left unattended.



BM25A hot bain marie pictured



BR25 refrigerated bain marie pictured with pans added

FEATURES - REFRIGERATED

- Refrigerated cold plate* running high quality R404A refrigerant
- Refrigerated condensing units can be supplied separately for remote installation
- Streamlined for easy cleaning
- Adjustable digital thermostat with temperature readout
- Quiet operation

See pages 54 - 56 for all optional accessories.

Note: All BM and BR bain maries can be manufactured with no corner legs for drop-in bench mounting. When ordering please specify by prefixing the model number with the letters NC e.g. NCBM24 (NC signifies 'no corner legs').
These items are made to order and are non-returnable.

*Safety regulations require careful preparation, handling and storage of food products at all times. Cold plate units operate with a single refrigeration coil attached to the underside of the tank, thus food is chilled from underneath. Users must be absolutely certain that a single refrigeration coil will suit their purpose and is in compliance with food safety standards.

SPECIFICATIONS

MODEL	POWER Watts	PAN COMBINATION	CURRENT Amps	DIMENSIONS w x d x h (mm)
HOT - PANS INCLUDED				
BM14A	1650	4 x 1/2 size x 100 mm ~	7.2	1135 x 408 x 255
BM16A	1550	6 x 1/2 size x 100 mm ~	6.7	1665 x 408 x 255
BM22A	1200	4 x 1/2 size x 100 mm ~	5.2	705 x 615 x 255
BM23A	1800	6 x 1/2 size x 100 mm ~	7.8	1030 x 615 x 255
BM24A	2700	8 x 1/2 size x 100 mm ~	11.7	1355 x 615 x 255
BM25A	2700	10 x 1/2 size x 100 mm ~	11.7	1680 x 615 x 255
BM26A	2700	12 x 1/2 size x 100 mm ~	11.7	2005 x 615 x 255
REFRIGERATED - PANS NOT INCLUDED				
BR22	480	4 x 1/2 size #	2.1	705 x 615 x 255 [†]
BR23	480	6 x 1/2 size #	2.1	1030 x 615 x 255 [†]
BR24	500	8 x 1/2 size #	2.2	1355 x 615 x 255 [†]
BR25	500	10 x 1/2 size #	2.2	1680 x 615 x 255 [†]
BR26	500	12 x 1/2 size #	2.2	2005 x 615 x 255 [†]

~ Pans and lids included. #Pans and lids not included. †Height dimensions exclude motor cage.

Note: Maximum pan depth 100 mm on all hot models and 65 mm on all refrigerated models. The BM series is also available without pans, delete "A" from the Model No.

Roband bain maries are designed to accommodate pans available from Roband Australia. Although other brands of pans may fit, this is not guaranteed due to variations in other manufacturers' pans.

Straight Glass Hot Food Display Bars

The straight glass hot food display bars have streamlined styling that will enhance food presentation whilst keeping the food at the correct serving temperature. A wide range of sizes and options are available to cater for numerous combinations of gastronorm pans up to 100 mm deep. Set of 1/2 size 65 mm pans included.

FEATURES

- Stainless steel construction with tubular frame
- Overhead heating and illumination by stylish heat lamps manufactured from extruded aluminium, specifically designed to breathe
- Energy regulator control
- Wet or dry operation^
- Dura-life stainless steel elements for prolonged element life
- Safety lock ball valve drain
- Streamlined for easy cleaning
- Removable cross bars
- Thermometer

^ Machines should not be left unattended.

See pages 54 - 56 for all optional accessories.

SPECIFICATIONS

MODEL	POWER Watts	NO. OF PANS	CURRENT Amps	DIMENSIONS w x d x h (mm)
SINGLE ROW				
E14 / E14RD	2150	4	9.4	1135 x 420 x 675
E16 / E16RD	2300	6	10.0	1665 x 420 x 675
DOUBLE ROW				
E22 / E22RD	1450	4	6.3	705 x 615 x 675
E23 / E23RD	2300	6	10.0	1030 x 615 x 675
E24 / E24RD	3200	8	13.9	1355 x 615 x 675
E25 / E25RD	3450	10	15.0	1680 x 615 x 675
E26 / E26RD	3450	12	15.0	2005 x 615 x 675



E14 (single row) pictured



E24 (double row) pictured with various sizes of pans

Safety lock ball valve drain



Temperature gauge

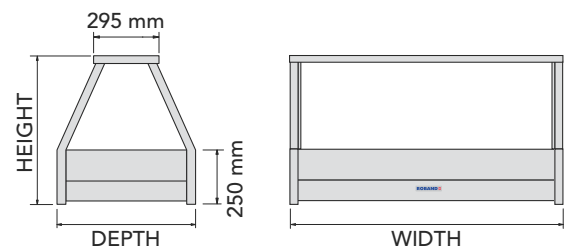

Note: RD signifies roller doors included. Sneeze guards cannot be fitted to the control panel side of single row foodbars when roller doors are installed.

Note: Hot food display bars are suitable for short-term food display. They are not a suitable substitute for a chicken humidifier.

They are also designed to accommodate pans available from Roband Australia. Although other brands of pans may fit, this is not guaranteed due to variations in other manufacturers' pans. Hot food display bars are designed to be served around and not over. If units are to be used in a serve over capacity, protection from hot surfaces will need to be considered. Environmental influences will affect the operating performance of hot food displays. Consideration should be given to food types, air movement and ambient temperatures before specifying. For dry, fried foods, Roller Doors are highly recommended.

Straight Glass Refrigerated Display Bars



These units match the range of "E" series hot food display bars and together they offer the combination of displaying hot and cold foods with uniform, modern appearance. They are designed to take a variety of gastronorm pans up to 65 mm deep. All units combine the use of cold plate and cross fin coil cooling. Set of 1/2 size 65 mm pans included.

FEATURES

- All stainless steel construction with tubular frame
- Refrigerated cold plate and cross fin coil technology
- ERX models feature a quality refrigeration unit running on environmentally friendly R404A refrigerant
- Overhead fluorescent light
- Quiet operation
- Safety lock ball valve drain
- Streamlined for easy cleaning
- Adjustable digital thermostat with temperature readout
- Removable cross bars
- Rear roller doors fitted as standard

See pages 54 - 56 for all optional accessories.



ERX23RD pictured with various sizes of pans

SPECIFICATIONS

MODEL	NO. OF PANS	POWER Watts [^]	CURRENT Amps	DIMENSIONS w x d x h (mm)
REFRIGERATED COLD PLATE & CROSS FIN COIL				
ERX23RD	6	530	2.3	1030 x 615 x 675
ERX24RD	8	625	2.7	1355 x 615 x 675
ERX25RD	10	815	3.5	1680 x 615 x 675
ERX26RD	12	815	3.5	2005 x 615 x 675
COLD PLATE & CROSS FIN COIL - PIPED & FOAMED ONLY (NO MOTOR)				
EFX23RD	6	30	0.2	1030 x 615 x 675
EFX24RD	8	45	0.3	1355 x 615 x 675
EFX25RD	10	45	0.3	1680 x 615 x 675
EFX26RD	12	45	0.3	2005 x 615 x 675

[^]Nominal ref. capacity.

Note: RD signifies roller doors included. EFX units are piped and foamed for remote installation and include control panel, thermometer & light and a cage to hold a refrigeration unit (refrigeration unit is not included for EFX range).

Roband food display bars are designed to accommodate pans available from Roband Australia. Although other brands of pans may fit, this is not guaranteed due to variations in other manufacturers' pans.

Adjustable digital thermostat, 0 °C to 8 °C

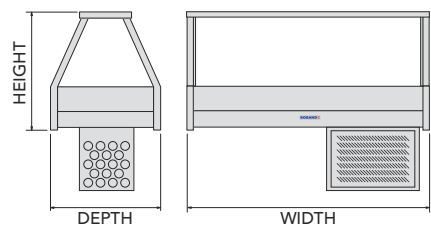

Note: For overall height dimensions, add height of motor cage (450 mm).

Curved Glass Hot Food Display Bars



The latest in curved glass hot food display bar design allowing full visual display of your presentations while maintaining correct serving temperature.

A wide range of sizes and options are available to cater for numerous combinations of gastronorm pans up to 100 mm deep. Set of 1/2 size 65 mm pans included.

FEATURES

- Stainless steel construction with tubular frame
- Overhead heating and illumination by stylish heat lamps manufactured from extruded aluminium, specifically designed to breathe
- Energy regulator control
- Wet or dry operation[^]
- Double skin tank for lower running costs
- Dura-life stainless steel elements for prolonged element life
- Safety lock ball valve drain
- Toughened safety glass front
- Streamlined for easy cleaning
- Removable cross bars
- Thermometer

[^] Machines should not be left unattended.

See pages 54 - 56 for all optional accessories.



C24 pictured

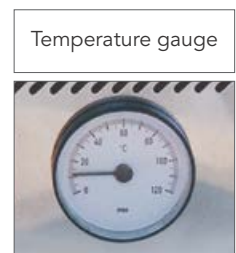
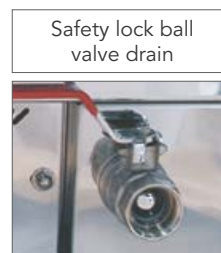

SPECIFICATIONS

MODEL	POWER Watts	NO. OF PANS	CURRENT Amps	DIMENSIONS w x d x h (mm)
DOUBLE ROW				
C22 / C22RD	1450	4	6.3	700 x 615 x 750
C23 / C23RD	2300	6	10.0	1030 x 615 x 750
C24 / C24RD	3200	8	13.9	1355 x 615 x 750
C25 / C25RD	3450	10	15.0	1680 x 615 x 750

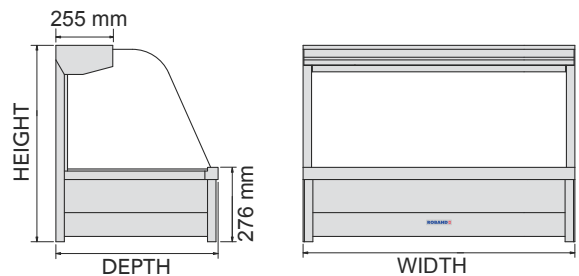

Note: RD signifies roller doors included. Sneeze guards cannot be fitted to the vertical control panel side when roller doors installed.

Note: Hot food display bars are suitable for short term food display. They are not a suitable substitute for a chicken humidifier. They are also designed to accommodate pans available from Roband Australia. Although other brands of pans may fit, this is not guaranteed due to variations in other manufacturers' pans. Hot food display bars are designed to be served around and not over. If units are to be used in a serve over capacity, protection from hot surfaces will need to be considered. Environmental influences will affect the operating performance of hot food displays. Consideration should be given to food types, air movement and ambient temperatures before specifying. For dry, fried foods, Roller Doors are highly recommended.

Curved Glass Refrigerated Display Bars

These units match the complete range of curved glass hot food display bars. Together they offer a stylish visual display to enhance your product. Designed to take a variety of gastronorm pans up to 65 mm deep. All units combine the use of cold plate and cross fin coil cooling. Set of 1/2 size 65 mm pans included.

FEATURES

- All stainless steel construction with tubular frame
- Refrigerated cold plate and cross fin coil technology
- Quality refrigeration unit running on environmentally friendly R404A refrigerant
- Overhead fluorescent light
- Quiet operation
- Double skin construction
- Safety lock ball valve drain
- Streamlined for easy cleaning
- Toughened safety glass front
- Adjustable digital thermostat with temperature readout
- Removable cross bars
- Rear roller doors fitted as standard



CRX24RD pictured

Adjustable digital thermostat, 0 °C to 8 °C



See pages 54 - 56 for all optional accessories.

SPECIFICATIONS

MODEL	NO. OF PANS	POWER Watts [^]	CURRENT Amps	DIMENSIONS w x d x h (mm)
REFRIGERATED COLD PLATE & CROSS FIN COIL				
CRX23RD	6	530	2.3	1030 x 615 x 750
CRX24RD	8	625	2.7	1355 x 615 x 750
CRX25RD	10	815	3.5	1680 x 615 x 750
COLD PLATE & CROSS FIN COIL - PIPED & FOAMED ONLY (NO MOTOR)				
CFX23RD	6	30	0.2	1030 x 615 x 750
CFX24RD	8	45	0.3	1355 x 615 x 750
CFX25RD	10	45	0.3	1680 x 615 x 750

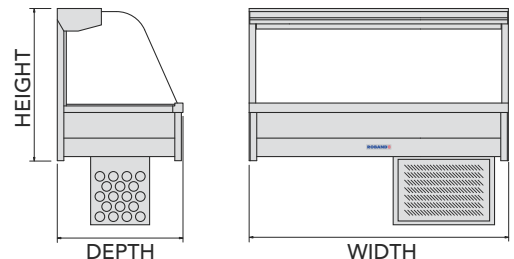

Note: For overall height dimensions, add height of motor cage (450 mm).

[^]Nominal ref. capacity.

Note: RD signifies roller doors included. CFX units are piped and foamed for remote installation and include control panel, thermometer & light and a cage to hold a refrigeration unit (refrigeration unit is not included for CFX range).

Roband food display bars are designed to accommodate pans available from Roband Australia. Although other brands of pans may fit, this is not guaranteed due to variations in other manufacturers' pans.

Square Glass Hot Food Display Bars



The square glass profile hot food display bars boast the latest in styling and design, at the same time offering all the features and reliability expected of a Roband product. They can be built-in, bench mounted or supplied with a trolley to suit. A wide range of gastronorm pan sizes available up to 100 mm deep. Set of 1/2 size 65 mm pans included.

FEATURES

- Stainless steel construction with tubular frame
- Overhead heating and illumination by stylish heat lamps manufactured from extruded aluminium, specifically designed to breathe
- Energy regulator control
- Wet or dry operation^
- Double skin tank for lower running costs
- Dura-life stainless steel elements for prolonged element life
- Safety lock ball valve drain
- Toughened safety glass front
- Streamlined for easy cleaning
- Removable cross bars
- Thermometer

^Machines should not be left unattended.

See pages 54 - 56 for all optional accessories.



S24 pictured

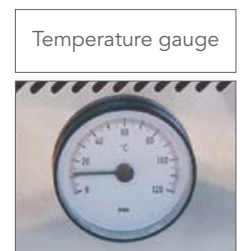
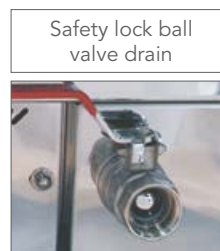

SPECIFICATIONS

MODEL	POWER Watts	NO. OF PANS	CURRENT Amps	DIMENSIONS w x d x h (mm)
DOUBLE ROW				
S22 / S22RD	1450	4	6.3	700 x 615 x 750
S23 / S23RD	2300	6	10.0	1030 x 615 x 750
S24 / S24RD	3200	8	13.9	1355 x 615 x 750
S25 / S25RD	3450	10	15.0	1680 x 615 x 750
S26 / S26RD	3450	12	15.0	2005 x 615 x 750

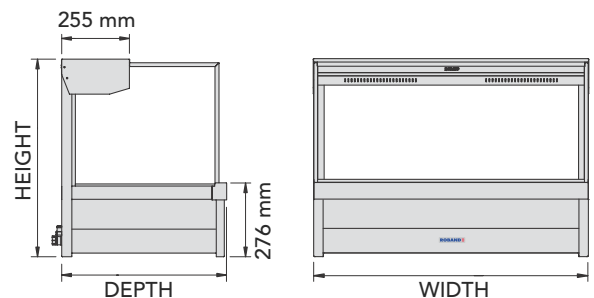

Note: RD signifies roller doors included. Sneeze guards cannot be fitted to the vertical control panel side when roller doors installed.

Note: Hot food display bars are suitable for short term food display. They are not a suitable substitute for a chicken humidifier. They are also designed to accommodate pans available from Roband Australia. Although other brands of pans may fit, this is not guaranteed due to variations in other manufacturers' pans. Hot food display bars are designed to be served around and not over. If units are to be used in a serve over capacity, protection from hot surfaces will need to be considered. Environmental influences will affect the operating performance of hot food displays. Consideration should be given to food types, air movement and ambient temperatures before specifying. For dry, fried foods, Roller Doors are highly recommended.

Square Glass Refrigerated Display Bars

These units match the complete range of square glass hot food display bars. Together they offer a stylish visual display to enhance your product. Set of 1/2 size 65 mm pans included. Max pan depth 65 mm. All units combine the use of cold plate and cross fin coil cooling. Set of 1/2 size 65 mm pans included.



SRX25RD pictured

FEATURES

- All stainless steel construction with tubular frame
- Refrigerated cold plate and cross fin coil technology
- Quality refrigeration unit running on environmentally friendly R404A refrigerant
- Overhead fluorescent light
- Quiet operation
- Double skin construction
- Safety lock ball valve drain
- Streamlined for easy cleaning
- Toughened safety glass front
- Adjustable digital thermostat with temperature readout
- Removable cross bars
- Rear roller doors fitted as standard



See pages 54 - 56 for all optional accessories.

SPECIFICATIONS

MODEL	NO. OF PANS	POWER Watts [^]	CURRENT Amps	DIMENSIONS w x d x h (mm)
REFRIGERATED COLD PLATE & CROSS FIN COIL				
SRX23RD	6	530	2.3	1030 x 615 x 750
SRX24RD	8	625	2.7	1355 x 615 x 750
SRX25RD	10	815	3.5	1680 x 615 x 750
SRX26RD	12	815	3.5	2005 x 615 x 750
COLD PLATE & CROSS FIN COIL - PIPED & FOAMED ONLY (NO MOTOR)				
SFX23RD	6	30	0.2	1030 x 615 x 750
SFX24RD	8	45	0.3	1355 x 615 x 750
SFX25RD	10	45	0.3	1680 x 615 x 750
SFX26RD	12	45	0.3	2005 x 615 x 750

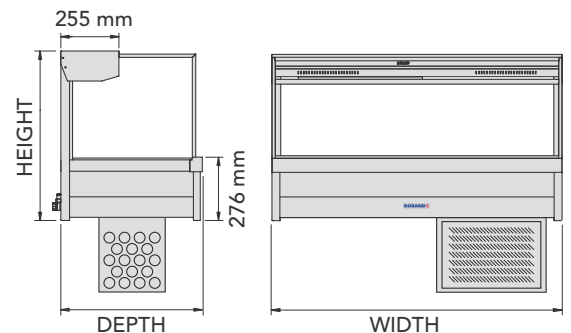

Note: For overall height dimensions, add height of motor cage (450 mm).

[^]Nominal ref. capacity.

Note: RD signifies roller doors included. SFX units are piped and foamed for remote installation and include control panel, thermometer & light and a cage to hold a refrigeration unit (refrigeration unit is not included for SFX range).

Roband food display bars are designed to accommodate pans available from Roband Australia. Although other brands of pans may fit, this is not guaranteed due to variations in other manufacturers' pans.

Food Bar and Bain Marie Accessories

Sneeze Guards

A must for self service areas, sneeze guards help prevent food contamination without detracting from the aesthetics of any food displayed. Small sneeze guards are available to suit control panel side of square and curved food display bars and single row straight food display bars. Note: Sneeze guards cannot be fitted to the rear control side of these machines when roller doors are installed.

Larger sneeze guards to suit front panel of single row straight "E" series food display bars or either side of double row straight "E" series food display bars. They can be fitted on the angled face of "E" series machines with or without roller doors.

Tray Races

Suited to all "E", "C" & "S" series food display bars, tray races provide an ideal serving counter or food preparation area. Made from high quality stainless steel at a depth of 207 mm these units are supplied loose to be affixed on site at the desired height.

Models TR14, 16, 22, 23, 24, 25 and 26.

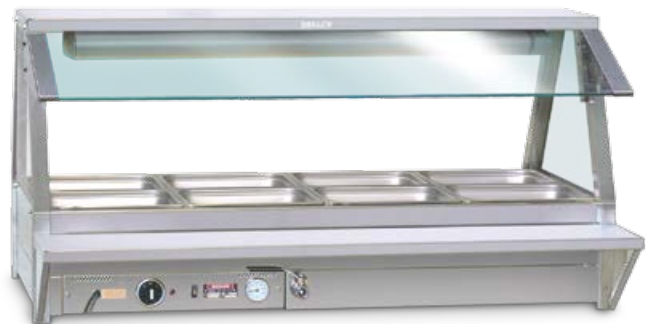

E24 pictured with E-SNZ24 sneeze guard and TR24 tray race

Chicken Trays

Sized to drop into double row food display bars and utilising all stainless steel construction these trays provide the ideal method to display cooked chickens. With a removable perforated insert these trays present no difficulties in cleaning and will ensure chickens stay hot and moist without pooling of oil.

Combinations of trays will cover the entire range of food display bars.

Models ECT22 (535 x 625 mm) and ECT23 (535 x 950 mm).



ECT23 chicken tray pictured

Stainless Steel Midshelves

Featuring robust stainless steel construction, Roband midshelves are designed to suit double row foodbars, with 3 sizes available. The midshelves provide additional storage space for items which don't need to be kept at a specific temperature like condiments, salt & pepper, take-away containers and more. The midshelf design provides a raised bar on one length of the shelf to avoid items falling off the shelf.

MODEL	To suit	DIMENSIONS w x d x h (mm)
SM22	2 x 2 pan foodbars	653 x 226 x 220
SM23	2 x 3 pan foodbars	978 x 226 x 220
SM24	2 x 4 pan foodbars	1303 x 226 x 220



SM23 pictured

Food Bar and Bain Marie Accessories cont'd

Food Bar / Bain Marie Trolleys

Designed to suit double row units these trolleys are solidly constructed, easy to assemble and include four castors for mobility. Two castors include brakes to ensure safe and sturdy functionality. All units include under-shelf. Supplied flat-packed for self-assembly. Models ET22, 23, 24, 25 and 26 suit double row "E", "C" & "S" series food display bars.

Also suits models BM22-BM26 & BR22-BR26 bain maries.

Trolley Panels

High quality stainless steel panels are available to suit each trolley size, improving the aesthetics and functionality of any given display application. Panels enclose the front and both ends of the corresponding sized trolley. Models ETP22, 23, 24, 25 and 26.



ET25 trolley pictured, with ETP25 panels

Single & Double Hob

An absolute must for serving soups, these hobs enable the fitting of 7.25 L round pots to BM1, BM2 and BM4 bain maries.

Made from high quality stainless steel these simple additions make counterline bain maries even more versatile.

Models BMH1 & BMH2.



BMH1 & BMH2 pictured

Insert Hob

Raised in profile this hob allows the fitting of a 7.25 L round pot into our range of hot food display bars and bain maries. Care needs to be taken to check where the raised pot fits into units with angled or curved glass. Model BMH3.



BMH3 pictured

Cross Bars

Available in two lengths these cross bars will provide support to combinations of smaller sized pans. With stainless steel construction and ease of removal for cleaning these additions will expand the functionality of any food display bar.

Models ECB1 (short - 30 cm) and ECB2 (long - 51 cm).



ECB1 & ECB2 pictured

Food Bar and Bain Marie Accessories cont'd

Food Bar / Bain Marie Pan Layout Guide

The Pan Layout Guide can be used to help plan what combinations of pans and cross bars are possible with Roband Food bars and Bain Maries.

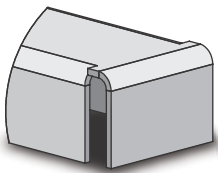
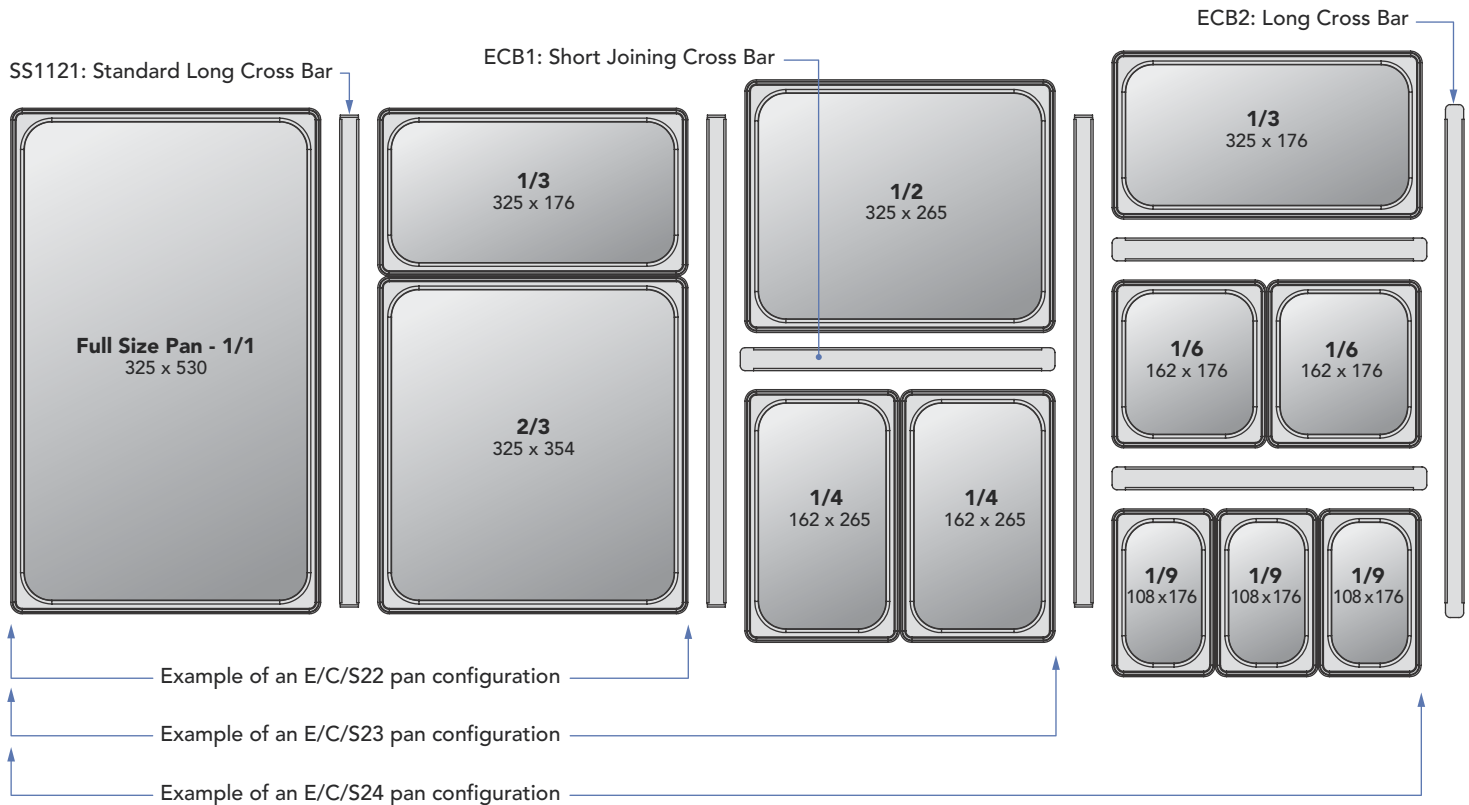

SS1121: This cross bar can only be inserted into the slots in double row tanks

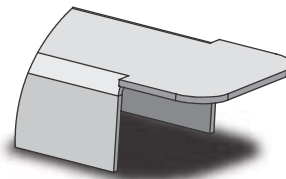

ECB1 and ECB2: These cross bars can be used in any position to allow pans to be supported

INFORMATION

- The drawing shows a double row module configuration
- When dividing up modules, ensure that each pan is supported on a minimum of two opposite sides. Use cross bars and tank sides to achieve the recommended support. ECB1 and ECB2 are available for this purpose.
- Use ECB1 and ECB2 to divide modules up into smaller sizes to accommodate varying pan combinations.
- The standard cross bar shown (SS1121) is supplied with all double row units. It is not normally necessary to purchase additional quantities of these parts.



E24 pictured with various pans

Rotisserie



The Roband rotisserie has the capacity to cook up to ten size 18 chickens at once and is the ideal solution for small to medium sized chicken outlets. The spit type rotisserie action ensures an evenly cooked product with minimum shrinkage and heat loss.

FEATURES

- Fast - thermo-reflective element technology cooks chickens even faster while keeping them moist
- Efficient - separate spit controls allow single spit operation in quiet periods to cut power consumption
- Large capacity - ten size 18 chickens*
- Twin glass doors for closer, easier access to remove chickens and minimise heat loss
- Easy to clean - removable doors, front glass and large grease drawer
- Strong construction - stainless steel body, spits and prongs
- Toughened safety glass



R10 pictured

Large capacity - ten size 18 chickens

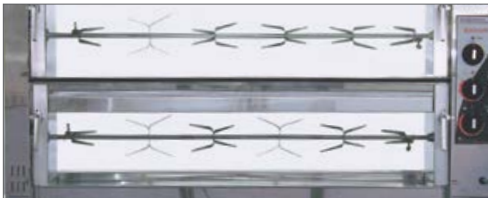

Large removable grease drawer



Fast cooking element technology



Removable doors and reflectors



Separate spit control for greater efficiency



SPECIFICATIONS

MODEL	CHICKENS No.	POWER Watts	CURRENT Amps	DIMENSIONS w x d x h (mm)
R10	10	3450	15.0	1185 x 360 x 675

*Note: Chicken sizes are determined by the chicken's weight, therefore ten particularly large size 18 chickens may not fit. Also note that the legs and wings of the chickens must always be tied.

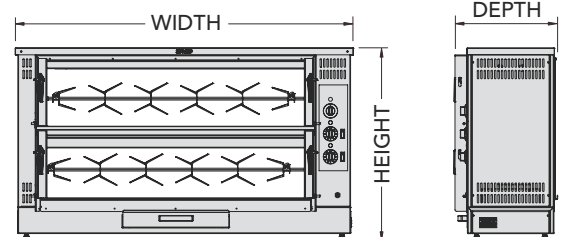

Freestanding Electric Fryers



The Austheat 3 phase electric fryers are ideal for take away shops or where high-speed production of fried food, such as fish and chips, is required.



AF812 pictured



AF822 pictured



AF813 pictured

AF812 Single Pan 29 Litres 14.5 kW

The Austheat AF812 has a single pan and comes complete with two heavy-duty, stainless steel baskets and lid. With robust stainless steel construction and a tank thickness of 1.5 mm, the AF812 will give you years of trouble free service in the production of quality fried foods.

AF812R (Rapid Recovery) 16.6 kW

Featuring 16.6 kW of power the AF812R is designed to perform where the demand for quick recovery is extreme.

AF822 Twin Pan 2 x 14 Litres 14 kW

This compact high performance fryer has two separate tanks with individual controls. These provide the ability to operate the tanks at different temperatures, to separate flavours or to shut down one tank in quieter periods. The AF822 comes complete with two heavy-duty, stainless steel baskets, two lids and has all the features of the other fryers in the range.

AF813 Single Pan 39 Litres 16.6 kW

This high performance single pan fryer has been specifically designed for the production of high volumes of fish and chips. It is equipped with three heavy-duty, stainless steel baskets and a lid but can be used stand-alone for wet batters. Construction is similar to that of the AF812.

AF813R (Rapid Recovery) 21.5 kW

With 21.5 kW of power the AF813R is designed to perform in the most demanding environment.

Freestanding Electric Fryers cont'd

SPECIFICATIONS

MODEL	BASKETS No.	TOTAL POWER	TOTAL CURRENT Amps	PHASE	OIL CAPACITY	COOKING TIME* (per 1.5 kg)	HOURLY OUTPUT PER HOUR* (frozen), (thawed)	HEAT UP TIME (to 185 °C)
SINGLE TANK								
AF812	2	14.5 kW	63.0	3 (+N)	29 litres	2-3 mins	32 kg, 39 kg	10 mins
AF812R	2	16.6 kW	72.3	3 (+N)	29 litres	2-3 mins	35 kg, 42 kg	9 mins
AF813	3	16.6 kW	72.3	3 (+N)	39 litres	2-3 mins	40 kg, 49 kg	10 mins
AF813R	3	21.5 kW	93.6	3 (+N)	39 litres	2-3 mins	45 kg, 55 kg	8.5 mins
DOUBLE TANK								
AF822	2	14.0 kW	60.9	3 (+N)	2 x 14 litres	2-3 mins	32 kg, 39 kg	10 mins

*Approximate productivity 12 mm sq. blanched chips.

Electric vs Gas

The benefits of electric fryers are significant - from contributing to a cleaner work place, to providing financial savings. Maintaining a cooler, more pleasant work environment is possible as electric fryers generally add less heat to your kitchen than gas fryers. Additionally, as there is no gas flame, Austheat fryers deliver a cleaner, healthier working environment by not burning the available oxygen, or emitting burnt and unburned gases into your kitchen.

Longevity

Electric emersion elements tend to greatly outlast gas burners and their replacement costs are considerably less. Additionally, tank deterioration that is so prevalent in gas fryers is negligible in electric fryers.

Energy efficient

In electric fryers, the majority of the energy from electricity is supplied directly into the elements, which are immersed in the oil, providing a very energy efficient solution and quick recovery time when loading food into the fryer. In the case of gas fryers, much of the energy is ultimately lost in the flue.

High performance

Designed to achieve a balance of high output and fast recovery, Austheat electric fryers consistently deliver fried food of the highest quality, while maximizing the life of your oil.

Easy to clean

Austheat fryers feature elements that swing out and up in seconds, providing access to a smooth, open, square tank for easy cleaning. There are no gas pipes to clean around and under, nor awkward crevices to access to thoroughly clean as can be the case with gas fryers.

Freestanding Electric Fryers cont'd

Dual control thermostats for efficiency and peace of mind

Each tank has a cook/idle switch that allows you to quickly switch between two temperature settings. Each cook/idle switch is linked to two thermostats housed behind the bottom door – one thermostat can be programmed with a cook temperature and the other with an idle temperature setting, reducing operating costs. The dual thermostats provide peace of mind that in the unlikely event of a thermostat failure, where the secondary thermostat can be set to cook temperature to allow you to continue operating.

Rear castors and adjustable front legs for complete manoeuvrability



Fishplate, element cover and cool zone below elements to prolong your oil life



Open tank provides clear access for easy cleaning



Safety thermostats

All units are fitted as standard with manual reset over-temperature safety cut-outs.

Cool zone

All units are fitted as standard with manual reset over temperature safety cut-outs. All Austheat fryers provide a cool zone that collects crumbs. The cool zone prevents the burning of crumbs so that the oil is not tainted by a burnt flavour. It also prolongs the life of the oil.

Pan covers included. (AF822 pictured)

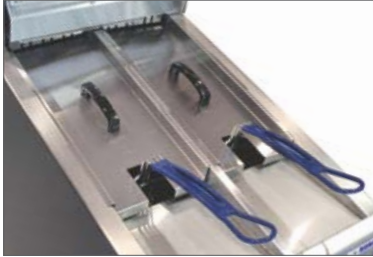

Fryers can be joined together modularly using the tank joining cover (SS1794)



Freestanding Electric Fryers cont'd

Melt cycles on all thermostats for use with solid cooking oil

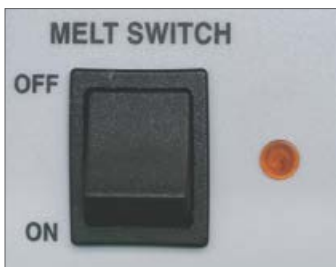

Melt cycles on all thermostats for use with solid cooking oil



Easy to read LED digital display



Cook idle switch for quick control



Dual control thermostats for peace of mind



Wide 25 mm (1") diameter drain pipe with lockable ball valve.



Tilt up elements for safe and easy cleaning of tank

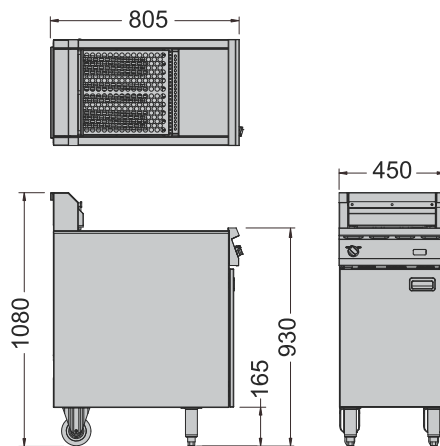

AF812 & AF812R dimensions (mm)

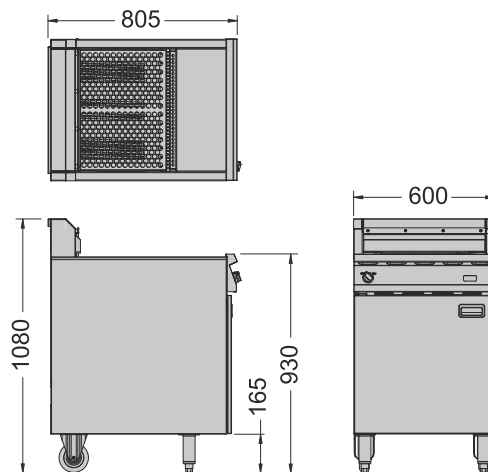

AF813 & AF813R dimensions (mm)

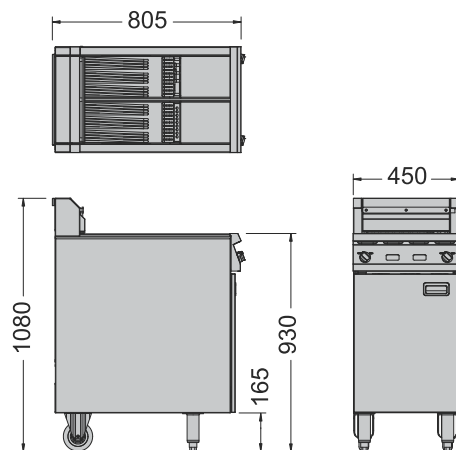

AF822 dimensions (mm)

Freestanding Hotplate/Grill



The electric Austheat hotplate griller is the ideal solution for busy fast food outlets where high speed grilling and toasting is required. Ideal as a hamburger or grill station, the Austheat hotplate/griller is designed to work either as a stand alone machine or alongside Austheat deep fryers in a modular configuration.

FEATURES

- A 12 mm thick heavy-duty machined steel hotplate cooking surface, providing the temperature and heat retention required for efficiently cooking foods such as hamburgers, steak, eggs, bacon and pancakes. Features separate controls for the left side and right side of the hotplate providing flexibility in the use of the cooking surface area and ability to conserve electricity by only heating the cooking surface space required.
- Each of the two cooking surface sections is controlled by it's own cook/idle switch. Each cook/idle switch has two thermostats - one to control the temperature when switched to "Cook" and the other to control the temperature when switched to "Idle". This feature allows the Chef to quickly turn the temperature of the machine up to "Cook" and down to an "Idle" heat setting in quieter times to conserve electricity. The twin thermostat has the added benefit of providing a backup in the unlikely event of a primary thermostat failure.
- Easily readable twin digital temperature displays depict plate temperature.
- The grill below the hotplate has a dedicated element for perfect one-sided toasting or salamander function. This is unlike many other brands available in the market that use the heat from the hotplate surface for toasting, which can result in uneven toasting. The heat output of the toaster is controlled by an energy regulator.
- The toaster also has a cook/idle setting. The twin energy regulator controls enable one heat setting to cook and another heat setting for idle periods so the chef can quickly switch between high and low settings in busy or quiet periods. It additionally provides a backup in the unlikely instance of a primary energy regulator failure.



AHT860 pictured

Freestanding Hotplate/Grill cont'd

Cook/idle switches.
Left controls 2/3 of plate,
right controls 1/3 of plate



Twin digital displays. One for
each side of the hotplate



Toasting section is controlled by a
separate energy regulator



SPECIFICATIONS

MODEL	HOTPLATE POWER	TOASTER POWER	TOTAL POWER	TOTAL CURRENT Amps	PHASE	COOKING PLATE AREA	APPROX. TOASTING AREA	TOASTING HEIGHT CLEARANCE
AHT860	10.5 kW	1.7 kW	12.5 kW	54.5	3 (+N)	645 x 585 mm	490 x 410 mm	135 mm

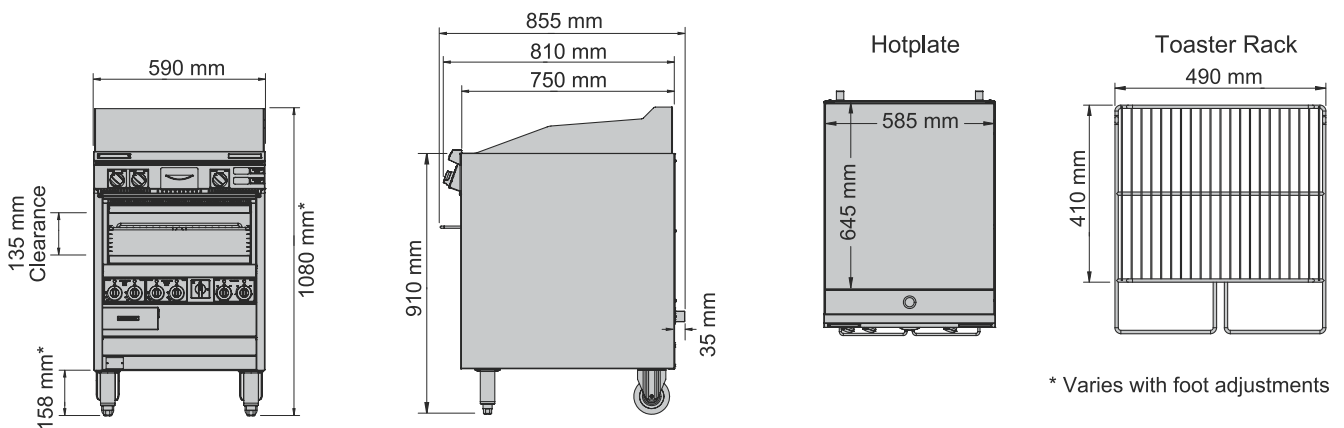

Operating Specifications and Disclaimers

Operating Specifications and Disclaimers

Dimensions detailed in this brochure are nominal only and may vary within tolerances from machine to machine.

Alterations to machine specifications may occur at any time due to ongoing research and development. Please check details with our offices for the latest information and specifications.

Performance specification evaluations are carried out under test conditions of either 230V 50Hz or 240V 50Hz. All standard Roband, Austheat and Robatherm products are designed to run at 230V per phase, 50Hz. Equipment to suit other voltages can typically be manufactured to order. Variations to indicative machine performance may occur as a result of variances in the voltage delivered to an installed unit. Lower voltages will result in significant reductions in performance, particularly in radiant-heat toasters (conveyor toasters, griller toasters etc.). Should you have any concerns in this regard, please contact our office and one of our technicians will discuss the issue with you.



Precautionary note

We recommend that only demineralised water be used with our products, for both cleaning and (if applicable) operational purposes. Water with high mineral content (also referred to as "hard water") may lead to corrosion of the stainless steel surfaces over time. The durability and longevity of other components may also be adversely affected by water with a high mineral content.

Additionally we counsel against the use of spray applicators, chemical cleaners and water jets in the cleaning of electrical equipment. The use of direct spray applicators can promote moisture ingress inside electrical switches and cause electrical failures. Chemical cleaners with low PH levels, particularly chloride based cleaners can damage stainless steel, aluminium, plastics and polycarbonates and should be avoided to ensure the longevity of any equipment.



Operating Specifications and Disclaimers cont'd

Warranty

Our machines are manufactured to the highest standards and every care is taken to ensure that all completed goods leave our factory in perfect working order and in pristine condition.

All Roband, Austheat and Robatherm machines are backed by a 12 month parts and labour warranty from the date of purchase. Additionally all units come with a comprehensive set of instructions detailing operation, safety and cleaning techniques. These instructions should be read in their entirety prior to operating any machine.

A written warranty also accompanies each machine, however details of the terms and conditions are available at any time on request. Typically, items such as glass, lamps and non-stick coating are excluded, but for full details please contact one of our offices.

The goods come with guarantees that cannot be excluded under the Australian Consumer Law (ACL). You are entitled to a replacement or refund for a major failure and for compensation for any other reasonably foreseeable loss or damage. You are also entitled to have the goods repaired or replaced if they fail to be of acceptable quality and the failure does not constitute a major failure.

Contact details for warranty:

Phone: 1800 268 848 (within Australia)

Email for Warranty: warranty@roband.com.au

Earth Leakage

Tubular heating elements (as used in most commercial heating equipment) may be subject to moisture absorption which can result in nuisance tripping of RCD's (Safety Switches). Although most cases can be solved easily by contacting our offices for advice, this is nevertheless an inherent characteristic of such elements and is not covered by warranty.

For further information regarding this or any other matter please contact our head office. Contact details can be found on the back cover of this brochure.

Notes

Notes

**Roband Australia Pty Ltd**

1 Inman Road,
Cromer, NSW 2099
Australia
Tel: +61 2 9971 1788
Fax: +61 2 9971 1336
Email: sales@roband.com.au

Roband (Europe) Ltd

Haygarth Park, Blaenau Ffestiniog
Gwynedd, North Wales
LL41 3PF, UK
Tel: +44 (0) 1766 830 456
Email: info@robandeurope.com

All standard Roband, Austheat and Robatherm products are designed to run at 230V per phase, 50Hz.

All dimensions are nominal only. All information contained in this brochure should serve as a guide only and is subject to change without notice due to constant research and development.

© 2020 Roband Australia Pty. Ltd. ACN 003 049 063 ABN 34 864 327 105

® is a registered trademark of Roband Australia Pty. Ltd.

Distributor: